

HP Series

NEMA-4X, high-performance industrial battery unit



Housing

- Compact gray fiberglass housing with captive screws
- NEMA-4X rated
- All external fasteners and hardware are constructed of stainless steel
- Die-cast aluminum LED heads

Mounting

- Simple and easy to install on walls, poles, columns, struts also on vertical
- Pole or column installation bracket sold separately (order catalog number: PMK1-E)
- 1/2" NPT conduit entry on top or side

Performance

- High temperature lead-calcium battery operates 32°F to 122°F (0°C to 50°C) optional cold-weather -40°F to 122°F (-40°C to 50°C)
- Nickel-cadmium battery operates 50°F to 104°F (10°C to 40°C)
- 6W, 10W and 15W high efficacy LED emergency heads
- 15W head outperforms traditional 50W MR16 halogen
- Innovative head design: four-LED and dual-driver provide illumination even in case of unexpected component failure

Power consumption - Maximum current draw

Temperature	Specs
Standard temperature range	120/277VAC, 60Hz, 0.30/0.15A
Cold-weather option	120/277VAC, 60Hz, 0.70/0.35A

Unit rating - non-CEC models

Model	Battery capacity in watts ¹			
	1-1/2 hrs	2 hrs	3 hrs	4 hrs
12HPM30	30	20	15	10
12HPM60	60	40	30	20
12HPN40	40	36	24	18
24HPN90	90	72	48	36

¹The cold-weather option is only rated for 90 minutes



Electronics

- Infra-red remote control tester included in all models: allows testing the equipment without the need to climb a ladder. Distance range up to 30 ft. Universal, one remote control tester may test all the units on the job
- Pulse plus charger
- Low voltage disconnect
- Automatic brownout protection
- Battery lock-out
- Fused output circuit
- Standard Advanced Diagnostics
- Optional Nexus®Pro IoT monitoring system
- Optional Nexus® wireless monitoring system
- 120/277 60Hz

Approvals

- UL 924 listed
- BC – California Energy Commission Title 20

Warranty

- 5-year limited warranty
- Detailed warranty terms located on page 202 or online at: www.emergi-lite.com/usa/files/EL_Warranty.pdf

Remote test control



Unit rating - CEC models

Model	Watts to 87-1/2% of rated battery voltage: standard Tamb range ¹			
	1-1/2 hrs	2 hrs	3 hrs	4 hrs
12HPM30	30	20	15	10
12HPM60	60	40	30	20

¹The cold-weather option is only rated for 90 minutes

©2021 ABB. All rights reserved. Rev: 01/2023

The Bluetooth® word mark and logos are registered trademarks owned by Bluetooth SIG, Inc. and any use of such marks by ABB Inc. is under license. Other trademarks and trade names are those of their respective owners.

Dimensions

Dimensions are approximate and subject to change.

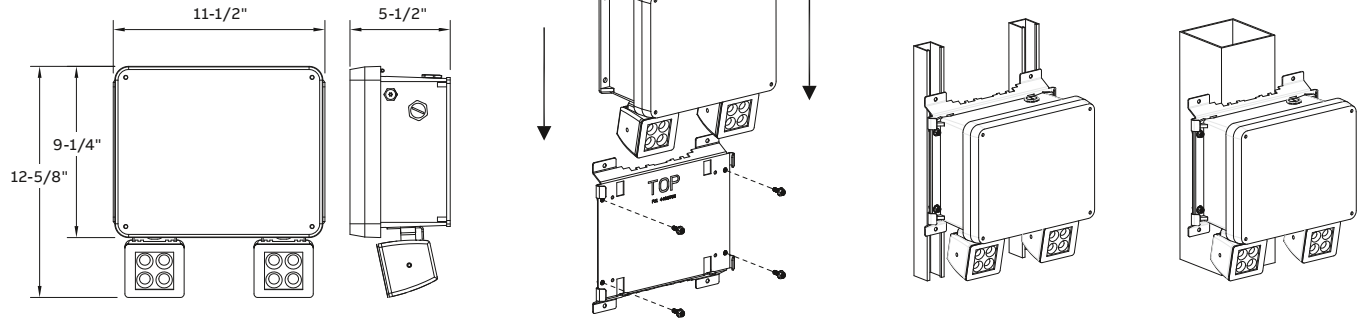

Photometric performance

Whether installed indoors or outdoors, the **HP Series** of LED emergency lights deliver a stable and consistent illumination on the path of egress for a wide range of mounting heights. Depending on the application, one may select and specify among three levels of lumen output. See cross reference to traditional incandescent emergency lights in table to the right.

LED head	Power	Total lumens	Out-perform spacing of incandescent lamps
L6	6W	565	35W PAR36, MR16 halogen
L10	10W	1000	50W PAR36, MR16 halogen
L15	15W	1300	50W MR16-IR halogen

Mounting height	Spacing center-to-center (feet)		
	Lamp L6 / 6W, 565LM	Lamp L10 / 10W, 1000LM	Lamp L15 / 15W, 1300LM
10 ft.	80	110	140
15 ft.	70	105	135
20 ft.	60	100	130
25 ft.	50	95	120

Industrial environment: wall mounted equipment, reflectances: 10/10/10; 6-ft. wide illumination path. 200 ft. X 200 ft. X 30 ft. space. Illumination as per NFPA101; Average: 1fc; Min: 0.1fc; Max/min < 40:1

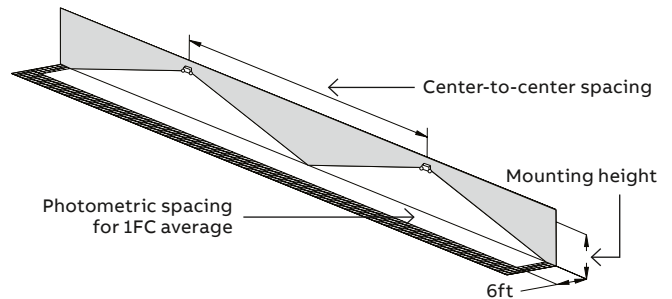

How to order

Series	Battery type and capacity	# of heads	LED heads	Diagnostic	Options	Approval
12HP = High-performance	Lead-calcium M30 = 12V-30W, high temperature lead-calcium battery, temperature= 32°F to 122°F [0...50°C] M60 = 12V-60W, high temperature lead-calcium battery, temperature= 32°F to 122°F [0...50°C]	0 = No head	L6 = 12-24V, 6W (565 Lumens) L10 = 12-24V, 10W (1000 Lumens) L15 = 12-24V, 15W (1300 Lumens)	D = Advanced Diagnostic, non-audible ¹ DA = Advanced Diagnostic, audible ¹ NEXP = Nexus®Pro IoT (contact your sales representative) ¹ NEXRF = Nexus® wireless (contact your sales representative) ¹	CW4 = Cold-weather - 40°F [-40°C] ² D3 = Time delay 15 minutes RFI = Radio frequency interference filter	-CEC = CEC Title 20 for California ³
		1 = One head				
		2 = Two heads				
24HP = 24V high-performance	Nickel-cadmium N40 = 12V-40W, nickel-cadmium battery, temperature= 50°F to 104°F [10...40°C] N90 = 24V-90W, nickel-cadmium battery, temperature= 50°F to 104°F [10...40°C]					

Example: 12HPN402L6DRFI

¹Standard - minimum load required: 20% of load capacity
²Only 12V equipment
³Available with lead-calcium models only