

# HP Series Remote Heads for Hazardous Locations

## *Class I Division 2, Class II, Division 2 Groups F & G, Class III*



**WARNING:**  
Risk of Electrical Shock.  
Disconnect Power before Installation.



### IMPORTANT SAFEGUARDS

When using electrical equipment, basic safety precautions should always be followed including the following:

### READ AND FOLLOW ALL SAFETY INSTRUCTIONS

1. All servicing should be performed by qualified service personnel.
2. Do not mount near gas or electric heaters.
3. Equipment should be mounted in locations and at heights where it will not readily be subjected to tampering by unauthorized personnel.
4. The use of accessory equipment not recommended by the manufacturer may cause an unsafe condition.
5. Do not use this equipment for other than intended use.

### SAVE THESE INSTRUCTIONS

#### Installation Instructions

1. Remove the cover from the back box (See figure 1).
2. Select the entry point on the back box for the conduit and open one of the knockouts (top or side).
3. Install the conduit fitting rated for Class 1 Div2 (provided).
4. For daisy-chain (input/output) wiring: open a second knockout and install the conduit fitting rated for Class 1 Div2 (provided).

#### Wall or Ceiling mount

Install the unit to the wall or ceiling with 4 screws (not included).

#### Column mount (option)

- a. The universal mounting bracket is an accessory ordered separately (See figure 2).
  - b. The bracket can be installed using steel banding for routing around the column. Standard banding (not provided) must be maximum 3/4-in in width. The bracket can also be mounted on a Superstrut® metal framing (1 5/8-in channel series) using 1/4-in bolts (not provided). Holes are placed at 9-in apart horizontally.
  - c. Install the bracket, observing the indicator: TOP.
  - d. Screw the unit onto the bracket with the 4 screws, washers and nuts included in the bracket kit.
5. Route the wires from the wire conduit(s) through the conduit fitting(s) and into the back box.

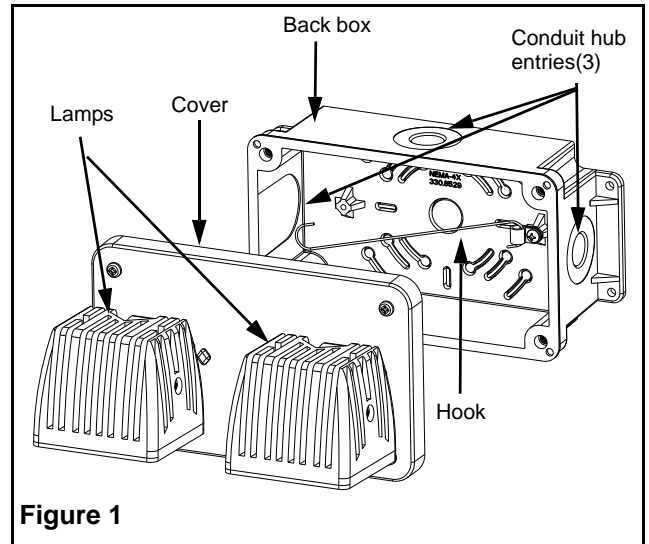

**Figure 1**

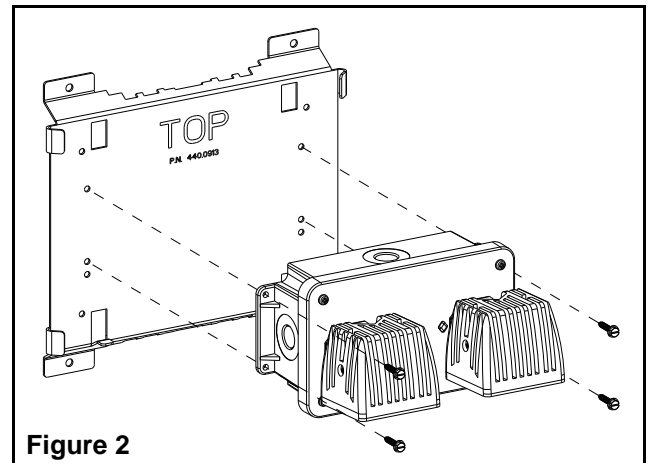

**Figure 2**



**WARNING:** THE COLUMN MUST BE ANCHORED TO THE FLOOR AND CEILING.

#### Maximum mounting height as per UL924 standards.

LED Lamp wattage	Maximum mounting height
6 - Watts	30 Feet
10 - Watts	50 Feet
15 - Watts	60 Feet

- Thread the wire conduit(s) tightly into the conduit fitting(s) ensuring a water-tight seal. If necessary, seal with silicone or equivalent caulking (not provided) to prevent water from leaking into the cabinet.

**WARNING:** FAILURE TO ENSURE A WATER-TIGHT INSTALLATION OF THE CONDUIT(S) AND FITTING(S) WILL VOID THE MANUFACTURER WARRANTY.

- Take the unit cover with lamps and hang it temporarily from the hook located inside the back box.
- Attach one of the ground wires to each screw located on the nut of the conduit fitting.
- Connect the left over ground wire(s) to the incoming wire conduit ground wire.
- Respecting the proper polarity {red (+) and black (-)}, connect the lamp wires to the emergency circuit (low-voltage 12-24Vdc) using wire nuts.
- Verify that the gasket is installed and well aligned in the groove of the cover.
- Unhook and install the cover onto the back box with the lamp heads pointing downwards. Tighten the four screws to prevent water infiltration.

**WARNING:** SCREWS MUST BE TORQUED TO AT LEAST 12INLB TO ENSURE A WATER-TIGHT SEAL BETWEEN THE COVER AND HOUSING.

- Adjust the lamp head assemblies:
    - Rotation: hold the lamp assembly and turn it to either side.
    - Tilting: hold the lamp assembly and tilt it up or down.
- If the lamp heads become loose: tighten the screws located on each side of the lamp heads and the nut located at the base of the bracket (See figure 3). **Warranty:** For the complete warranty information, please refer to the landing page of our website (<http://www.emergi-lite.com/usa/>).

