

EL-2RHL Series

High output lithium LED battery unit



Housing

- UV stabilized thermoplastic body
- Two adjustable high output LED lighting heads
- White finish

Mounting

- Wall or ceiling mount
- Universal J-box mounting

Lamp type

- Two 9.6V-5.4W LED heads, 550 lumens per head

Electronics

- Pulse plus charger
- Low voltage disconnect
- Automatic brownout protection
- Battery lock-out
- Fused output circuit
- Standard Advanced Diagnostics
- 120/277 60Hz

Dimensions

Dimensions are approximate and subject to change.

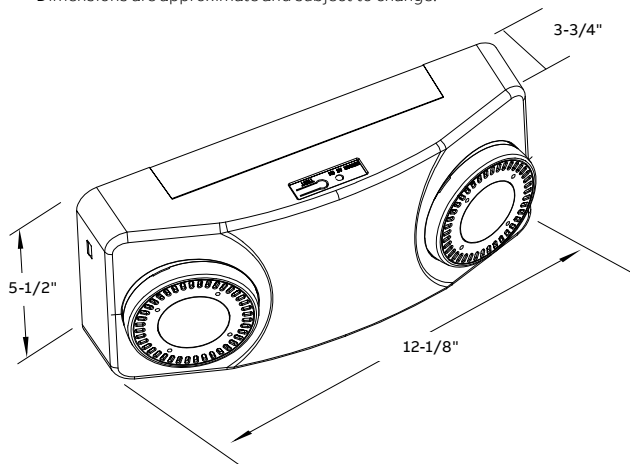

Approvals

- UL 924 Listed
- Damp location (50°F to 104°F)
- UL 94, 5VA flame rated
- Circle BC meet CEC title 20

Warranty

- Unit has a three-year warranty
- Detailed warranty terms located on page 202 of the catalog or online at:

www.emerigi-lite.com/usa/files/EL_Warranty.pdf

Power consumption and unit rating

Model	Battery type	DC specs		AC Specs
		Voltage	Units dual voltage	
EL-2RHL-AD	Lithium-ion battery	9.6		120-277

How to order

Series	Heads
EL	-2RHL-AD= Two round high output LED heads with Advanced Diagnostics

Example: EL-2RHL-AD

Photometry performance

Mounting height	Spacing center-to-center (feet)	
	6 ft spacing distance	
7.5'		90'
10'		78'

