

FPDL-32

EMERGILITE BRAND

INSTRUCTION MANUAL

IMPORTANT SAFEGUARDS

When using electrical equipment, basic safety precautions should always be followed, including the following:

READ AND FOLLOW ALL SAFETY INSTRUCTIONS

1. **CAUTION** - To prevent electrical shock, do not mate unit connector until installation is complete and A.C. power is supplied to the unit.
2. **CAUTION** - This fixture provides more than one power supply output source. To reduce the risk of electrical shock, disconnect both normal and emergency sources by turning off the A.C. Branch circuit and by disconnecting the unit connector.
3. The battery is sealed, non-maintenance, and is not replaceable in the field. Please contact manufacturer for information on service. Do not attempt to service the battery please.
4. **DO NOT USE OUTDOORS.** The product is for use with grounded, UL Listed, indoor fixtures except in heated air outlets or hazardous locations.
5. The product requires an unswitched A.C. Power source of either 120 or 277 volts. Properly cap the unused A.C. Lead.
6. Do not mount near gas or electric heaters.
7. The product should be mounted in locations and at heights where it will not readily be subjected to tampering by unauthorized personnel.
8. The product will cold strike and operate one 2' through 4' (20-40W) instant start, rapid start, U shape or circline, T8 through T12 fluorescent lamps, T5 28W fluorescent lamps, including energy saving and long compacts for 90 minutes at reduced light output.
9. The product is compatible with all A.C. magnetic and electronic ballasts including multiple lamp ballasts with one lamp operating in the emergency mode.
10. The use of accessory equipment not recommended by the manufacturer may cause an unsafe condition.
11. Do not use this equipment for other than intended use.
12. Install in accordance with the National Electrical Code and local regulations.
13. Installation and servicing should be performed by qualified personnel.
14. Lighting fixture manufacturers, electricians and end users need to ensure product system compatibility before final installation.
15. The battery is sealed, non-maintenance, and is not replaceable in the field. Please contact manufacturer for information on service. Do not attempt to service the battery please.
16. The rated operating time in the emergency mode with battery is 1-1/2 hours and the recharge time shall not be less than 24 hours.

SAVE THESE INSTRUCTIONS



INSTALLATION INSTRUCTIONS

CAUTION: Before installing, make certain the A.C. Power is off and the battery connector is disconnected.

1. MOUNTING THE FPDL-32

Remove the ballast channel cover. Mount the FPDL-32 in the ballast channel at least $\frac{1}{2}$ " away from the A.C. Ballast(s).

When battery packs are remote mounted, the remote distance can not exceed $\frac{1}{2}$ of the distance from ballast to lamp specified by the A.C. Ballast manufacturer. For example, if the A.C. Ballast manufacturer recommends no more than 25' remote distance, then the battery pack should not exceed 12 $\frac{1}{2}$ '. Under no circumstances should the battery pack exceed a distance of 50' from the lamp.

2. WIRING

Refer to the wiring diagrams on the back page for the appropriate wiring of lamp(s) and ballast. Install in accordance with the National Electrical Code and local regulations. For additional wiring diagrams consult Customer Service.

3. INSTALLING THE LIGHTED

Recessed Troffer Fixture - Select a convenient location with proper clearance in the ballast cover and drill or punch a $\frac{7}{8}$ " hole ($\frac{1}{2}$ " knockout). Insert the $\frac{7}{8}$ " bushing into the hole. Push the plastic tube through the bushing. Route the leads of the **INDICATOR LIGHT** through the plastic tube. Connect the LED wires from the unit to the **INDICATOR LIGHT** (Violet to Red, Brown to White/Red). Push the entire assembly back into the tube until the lens collar rests against the plastic tube. The plastic tube should be adjusted so that the **INDICATOR LIGHT** is within $\frac{1}{4}$ " of the fixture lens. The **INDICATOR LIGHT** must be visible after installation. Refer to *Illustration 1*.

Strip Fixture - Select a convenient location on the fixture so the **TBTS** can be seen after installation. Allow for proper clearance inside the fixture and drill or punch a $\frac{1}{2}$ " hole. Remove the nut from the **TBTS**. Push the **TBTS** housing into the $\frac{1}{2}$ " hole and secure with the nut. Connect the LED wires from the **TBTS** (Violet to Red, Brown to White/Red). Refer to *Illustration 2*.

Illustration 1

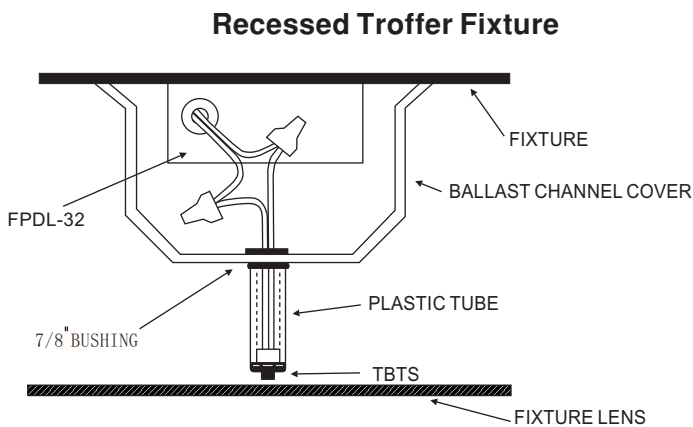
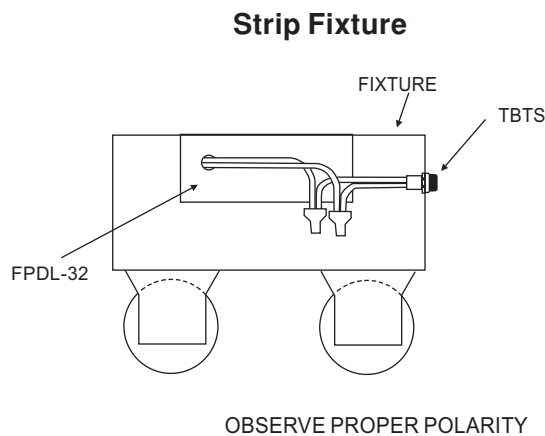

Illustration 2



4. WIRING THE A.C. INPUT

- The **FPDL-32** and A.C. Ballast must be on the same branch circuit.
- The **FPDL-32** requires an unswitched A.C. Power source of either 120 or 277 volts. Select the proper voltage lead and cap the unused lead.
- When the **FPDL-32** is used with a switched fixture, the A.C. Input to the **FPDL-32** must be connected ahead of the fixture switch. Refer to *Illustration 3* for switched and unswitched fixture wiring diagrams.

5. BALLAST WIRING BLOCK DIAGRAM

Illustration 3

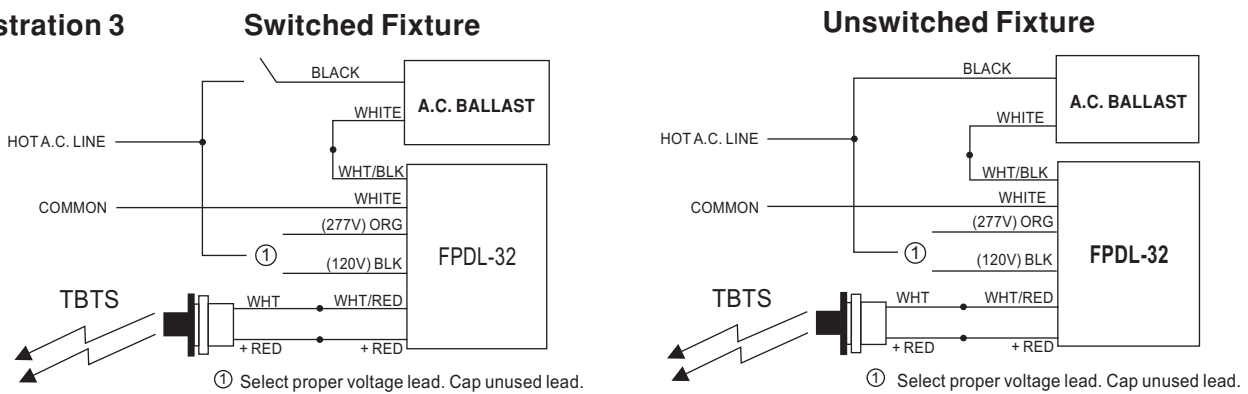

6. LABELS

Attach the appropriate labels adjacent to the **TBTS**. Annotate Re-lamping label for lamp type and wattage. The Caution and the Re-lamping labels must be on the fixture in a readily visible location to anyone attempting to service the fixture.

7. COMPLETING INSTALLATION

When the installation is complete, switch the A.C. power on and join the **FPDL-32** unit connector.

OPERATION

Normal Mode - A.C. power is present. The A.C. ballast operates the fluorescent lamp(s) as intended. The **FPDL-32** is in the standby charging mode. The **TBTS** will be lit providing a visual indication that the battery is being charged.

Emergency Mode - The A.C. Power fails. The **FPDL-32** senses the A.C. Power failure and automatically switches to the *Emergency Mode*. One lamp is illuminated, at reduced output, for a minimum of 90 minutes. When the A.C. Power is restored, the **FPDL-32** switches the system back to the *Normal Mode* and resumes battery charging. See page 1 of the Instruction Manual.

TESTING & MAINTENANCE

Pressing the red lens on the **TBTS** turns off the light on the **TBTS** and forces the unit into emergency mode. This interrupts power to the emergency lamps only. The emergency lamp is now being lit by the **FPDL-32** unit and will be less bright than the other lamps in the system. To simulate a "BLACK OUT" use the or circuit breaker to turn off A.C. Power.

Initial Testing - Allow the unit to charge approximately 1 hour, then press the **TBTS** to conduct a short discharge test. Allow a 24 hour charge before conducting 90 minute test.

The **FPDL-32** is a maintenance free unit, however, periodic inspection and testing is required. NFPA 101, Life Safety Code, outlines the following schedule:

Monthly - Insure that the **TBTS** is illuminated. Conduct a 30 second discharge test by depressing the **TBTS**. One lamp should operate at reduced output.

Annually - Insure that the **TBTS** is illuminated. Conduct a full 1 1/2 hour discharge test. The unit should operate as intended for the duration of the test.

"Written records of testing shall be kept by the owner for inspection by the authority having jurisdiction."

SERVICING SHOULD BE PERFORMED BY QUALIFIED PERSONNEL.

TYPICAL WIRING DIAGRAMS

Typical schematics only may be used other ballast, consult the factory wiring diagram

1. ONE LAMP RAPID START BALLAST

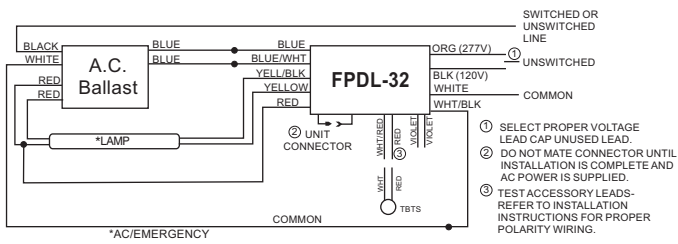

2. ONE LAMP INSTANT START BALLAST

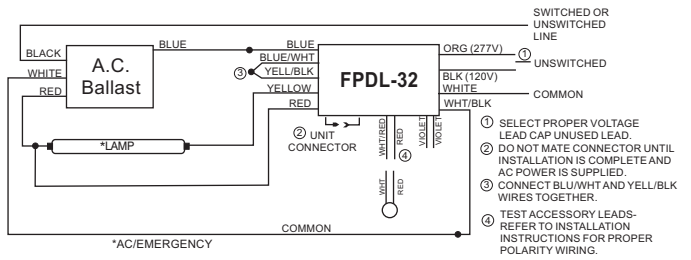

3. TWO LAMP RAPID START BALLAST

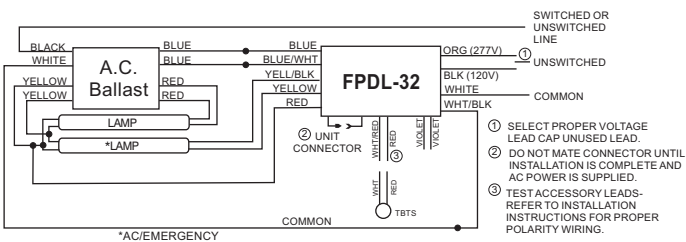

4. TWO LAMP INSTANT START BALLAST

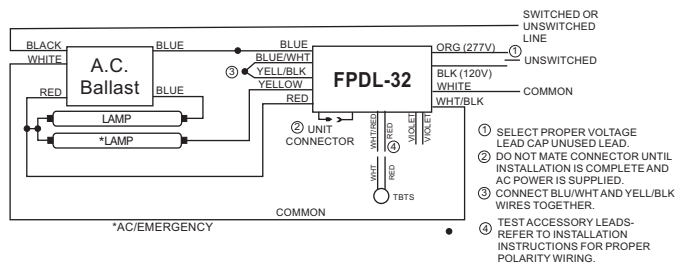

5. TWO LAMP T-5 SERIES YELLOW FILAMENT

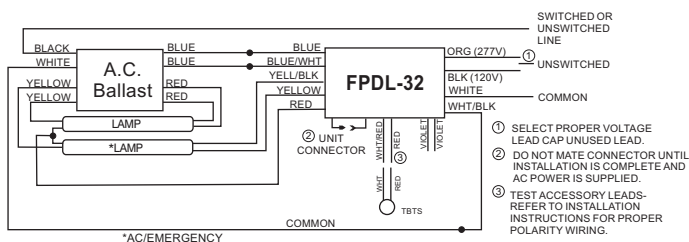

6. TWO LAMP OSRAM SYLVANIA ONLY PROGRAM RAPID START

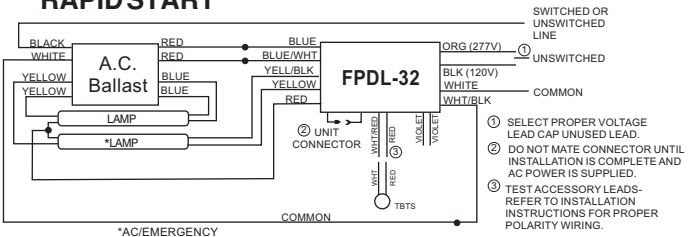

7. THREE LAMP RAPID START BALLAST

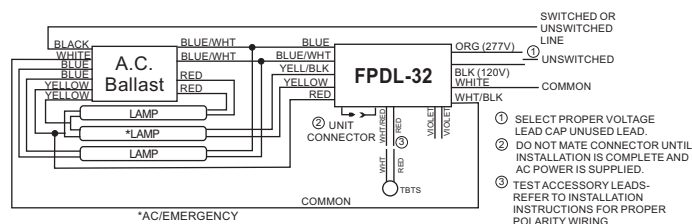

8. THREE LAMP INSTANT START BALLAST

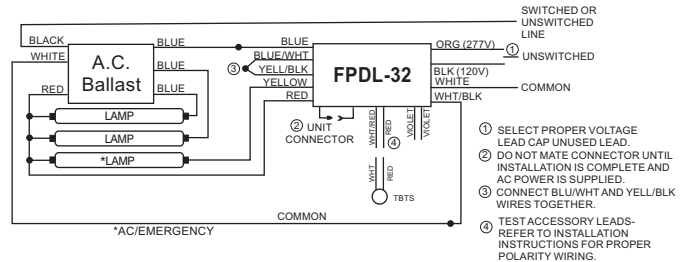

9. FOUR LAMP INSTANT START BALLAST

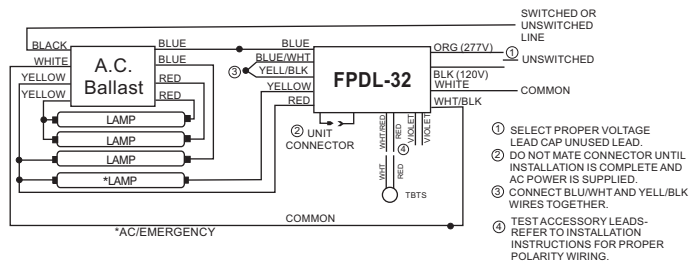

NOTE: Use the proper input voltage lead, cap unused lead

LAMP SELECTOR LEAD INSTRUCTIONS

This unit features Lamp Selector Leads (violet) for optimizing light output of specified lamps. The unit is shipped from the factory with the 6£leads disconnected and capped.

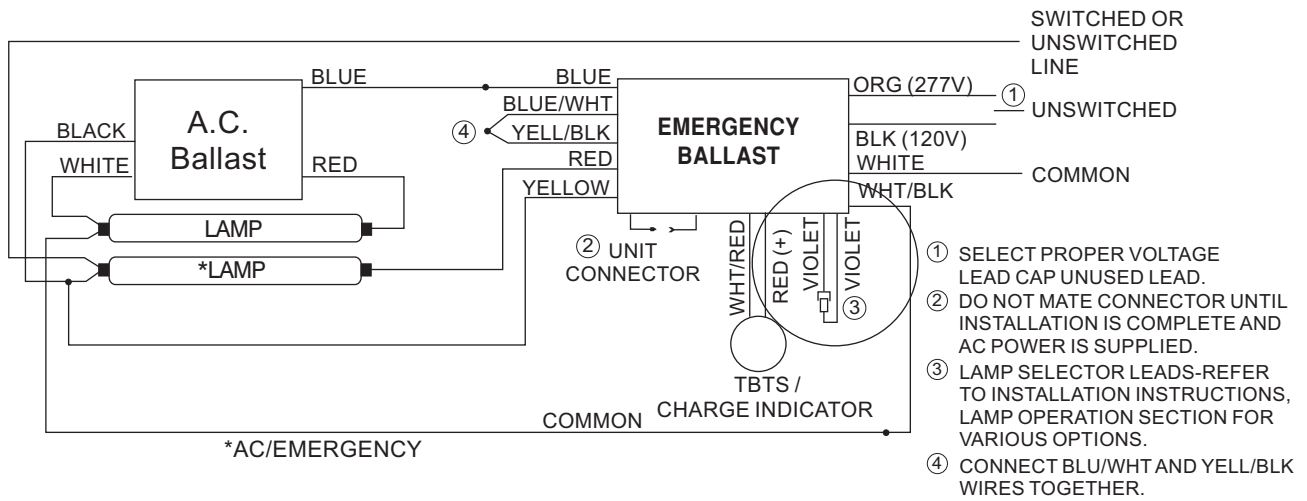

This unit can be used with most 2'-4' lamps. Refer to the chart below for the type of lamp(s) operated and the number of lamps to be operated in emergency mode.

OPTION	LAMP TYPE	EMERGENCY OPERATION	*VIOLET LEADS	WIRING DIAGRAMS
1	2 FT T8-T12 Single, Bipin (up to 20W)	One Lamp	Connected	1,2,3,4,5,6,7,8,9
2	4 FT T8-T12 Single, Bipin (20~40W) For T5 Lamp MAX, 28W	One Lamp	Disconnected	1,2,3,4,5,6,7,8,9