



EXHZ Series

Combination Unit for Hazardous Locations:
 Class I Zone 2 Groups: IIA, IIB and IIC
 Class I Division 2 Groups: A, B, C and D

Project/Location: _____

Contractor: _____

Date: _____

Prepared by: _____

Features

- Certified Class I Zone 2, Groups IIA, IIB and IIC
- Certified Class I Division 2, Groups A, B, C and D as per CSA C22.2 No.137-M1981
- Certified temperature Codes for several types of emergency lamps
- Certified CSA C22.2 No141
- Certified CSA C860
- Polymeric frame, with built-in gasket to prevent water infiltration
- Heavy-duty 1/8-inch thick aluminum back plate with key-holes for secure wall-mount installation
- Sealed faceplate of heavy-duty, vandal-resistant polycarbonate
- Suited for areas with the risk flammable gases, vapors or liquids that can create an explosive atmosphere
- Exit sign module illuminated by long-life, energy-efficient **AllInGap** red LEDs
- Two MR16 halogen lamps, shielded by a cast aluminum housing and a polycarbonate cover
- Sealed, maintenance-free, Lead-Calcium or Nickel-Cadmium batteries
- Remote load capacity
- Comes standard with auto-diagnostic functions
- Comes standard with industrial-grade, die-cast Aluminum electrical box
- 1/2-inch electrical conduit entry on both sides and at the top
- NEXUS[®] compatible (for more information on NEXUS[®], please contact your sales representative)



Typical Specification

Supply and install Emergi-Lite **EXHZ Series** combination of unit equipment and LED exit sign. Designed specifically for hazardous locations, the equipment frame shall be of industrial grade polymer with gaskets around both sides of the frame contour. The back plate shall be made of 1/8-inch thick aluminum sheet and shall include knockouts for installation on an electrical box and four keyholes for alternative installation on a wall surface.

The faceplate shall be constructed of heavy-duty vandal-resistant polycarbonate and feature a uniformly illuminated legend. The light source shall be light emitting diodes (LED). Red LED technology shall be **AllInGap**. An LED-sensitive diffuser shall be mounted behind the legend to provide the 6" high by 3/4" stroke letters with even illumination.

When specified, the equipment shall have attached a lower compartment containing two emergency lights with adjustable swivels and long-life MR-16 halogen or LED lamps of ___ V and ___ W. The lamps shall be shielded by a cast aluminum housing and protected by a shock-absorbent, transparent polycarbonate cover.

The equipment shall be certified for Hazardous Locations; Class I Zone 2 Groups: IIA, IIB and IIC and Class I Division 2 Groups: A, B, C and D. The standard AC input voltage shall be: 120/347Vac. The equipment shall be equipped with a magnetic test switch located behind the face plate and two LED pilot lights: AC-on and "Service required". The unit shall include auto-diagnostic functions monitored by a micro-controller and shall automatically self test for one minute every 30 days, 10 minutes in the 6th month and 30 minutes annually. The "Service required" LED shall light when a fault is detected. A four-LED diagnostic display located inside the equipment shall identify the source of the failure (battery, charger circuitry, or lamp load).

The exit sign module shall be CSA-C860 approved.

The combination unit shall be Emergi-Lite model: _____.

Dimensions

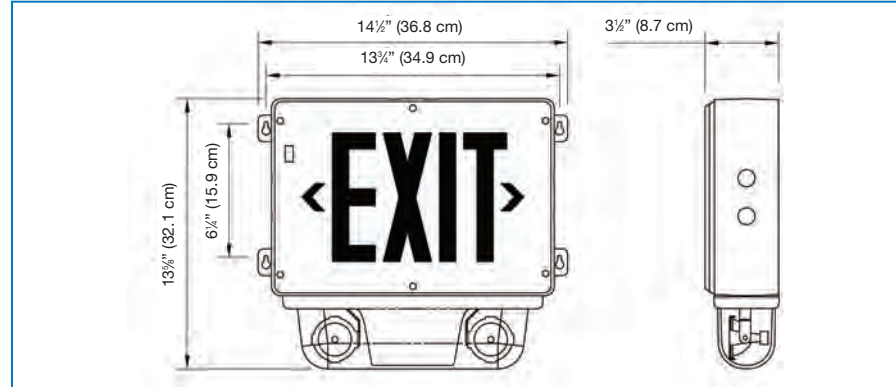

Wire Guards

460.0078-E Wall Mount

Power Consumption and Unit Rating

Model Number	AC Specs		Wattage Capacity				
			30min	1h00	1h30	2h00	4h00
EXHZL3	120 / 347Vac	0.15 / 0.06 Amp	36	21	15	12	-
EXHZN3		0.15 / 0.06 Amp	36	30	20	15	-
EXHZN6A		0.30 / 0.10 Amp	60	40	30	20	10

Temperature Codes

Lamp Rating	Temperature Code	Maximum Temperature	Replacement Part #
6V - 10W	T3C	160°C	580.0079-E
12V - 12W	T3A	180°C	580.0080-E
12V - 20W-H	T2D	215°C	580.0068-E

Note: Use qualified replacement lamps to avoid risk of over-heating

Ordering Information

Series	Housing/Face Color	Voltage	Capacity	Letter Color	Options	Number of Heads	Lamp/Wattage
EXHZ= combo Exit Class I Div. 2	GG= grey/grey	Blank= 120/347Vac 2= 120/277Vac	L3= 6V - 36W lead acid N3= 6V- 36W NiCad N6A= 12V - 60W NiCad	Blank= red letters G= green letters	U= auto-diagnostics, audible UN= auto-diagnostics, non-audible NEX= Nexus [®] system interface* *Consult your sales representative for options available with NEXUS [®] System.	Blank= 0 heads /2= two heads	MJ= 6V - 10 watts, MR16 MK= 12V - 12 watts, MR16 MW= 12V - 20 watts, MR16-IR

EXAMPLE: EXHZGGN3U12MJ