



HZM Series

Battery Unit for Hazardous Locations:
 Class I Zone 2 Groups: IIA, IIB and IIC
 Class I Division 2 Groups: A, B, C and D

Project/Location:
Contractor:
Date:
Prepared by:

Features

- Certified Class I Zone 2, Groups IIA, IIB and IIC
- Certified Class I Division 2, Groups A, B, C and D as per CSA C22.2 No.137-M1981
- Certified temperature Codes for several types of emergency lamps
- Suited for areas with the risk of flammable gases, vapors or liquids that can create an explosive atmosphere
- Certified CSA C22.2 No141
- Polymeric frame, with built-in gasket to prevent water infiltration
- Heavy-duty 1/8-inch thick aluminum back plate with keyholes for secure wall-mount installation
- Two MR16 halogen or LED lamps, shielded by a cast Aluminum housing and a polycarbonate cover
- Sealed, maintenance-free, Lead-Calcium batteries with up to 120W emergency power
- Built-in microcontroller-based battery charger and auto-diagnostic circuitry
- ½-inch electrical conduit entry on both sides and at the top
- NEXUS® compatible (for more information on NEXUS®, please contact your sales representative)



Typical Specification

Supply and install Emergi-Lite **HZM Series** of battery units. Designed specifically for hazardous locations, the equipment frame shall be of industrial grade polymeric metal with gaskets around both sides of the frame contour. The frame shall be fixed between two plates made of 1/8-inch thick aluminum sheet. The back plate shall include four keyholes for wall-mount installation. The front plate shall include two water-tight lenses for pilot lights: AC-on and "Service required". When specified, the equipment shall have attached a lower compartment containing two emergency lights with adjustable swivels and MR-16 halogen or LED lamps. The lamps shall be shielded by cast aluminum housing and protected by a shock-absorbent, transparent polycarbonate cover.

The equipment shall be certified for Hazardous Locations; Class I Zone 2 Groups: IIA, IIB and IIC and Class I Division 2 Groups: A, B, C and D. The standard equipment shall have a dual AC input voltage: 120/347Vac and shall be equipped with a magnetic test switch located on the left side of the frame.

The unit shall include self-testing/self-diagnostic functions monitored by a micro-controller and shall automatically self test for one minute every 30 days, 10 minutes in the 6th month and 30 minutes annually. The "Service required" LED shall light when a fault is detected. A four-LED diagnostic display located inside the equipment shall identify the source of the failure (battery, charger circuitry, lamp load).

The battery unit unit shall be Emergi-Lite model: _____.

Dimensions

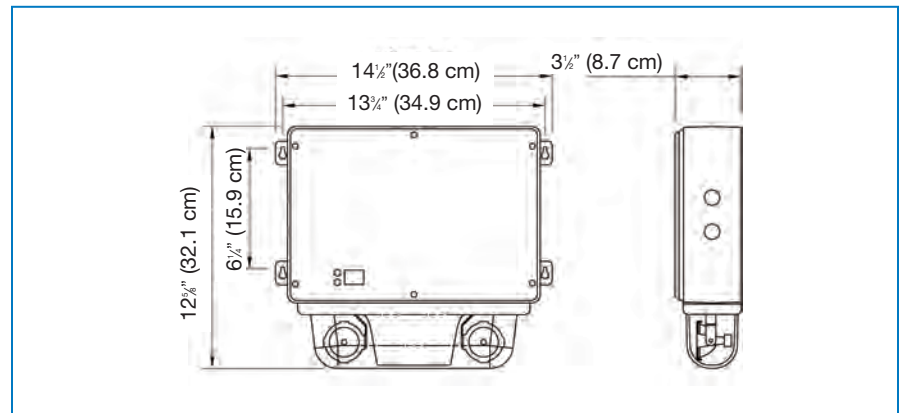

Wire Guards

460.0078-E Wall Mount

Power Consumption and Unit Rating

Model Number	AC Specs		Wattage Capacity				
			30min	1h00	1h30	2h00	4h00
HZM36	120 / 347Vac	0.17 / 0.06 Amp	36	21	15	12	-
HZM72		0.30 / 0.10 Amp	72	42	30	24	12
HZM120		0.30 / 0.10 Amp	120	70	50	40	20

Temperature Codes

Lamp Rating	Temperature Code	Maximum Temperature	Replacement Part #
6V - 10W	T3C	160°C	580.0079-E
12V - 12W	T3A	180°C	580.0080-E
12V - 20W-H	T2D	215°C	580.0068-E

Note: Use qualified replacement lamps to avoid risk of over-heating

Ordering Information

Series	Capacity	Colour	A.C. Voltage	Options	# of Heads	Lamp/Wattage
06HZM = 6 volts 12HZM = 12 volts	36 = 6V-36 watts 72 = 12V-72 watts 120 = 12V-120 watts	Blank = grey	Blank = 120/347Vac -2 = 277Vac	U = auto-diagnostics, audible UN = auto-diagnostics, non-audible (standard) NEX = Nexus® system interface*	/0 = No head /2 = 2 heads	MJ = 6V - 10 watts, MR16 MK = 12V - 12 watts, MR16 MW = 12V - 20 watts, MR16-IR LG = 12V - 4 watts, LED MR16

EXAMPLE: 06HZM36UN/2MJ