

HZM-Series-Class I, Div 2 Battery Unit

Installation instructions

IMPORTANT SAFEGUARDS

When using electrical equipment, basic safety precautions should always be followed including the following:

READ AND FOLLOW ALL SAFETY INSTRUCTIONS

1. Make sure the area is NON-HAZARDOUS before installing or servicing the unit.
2. Turn off electrical power before and during installation and maintenance.
3. Before opening, turn off electrical power and wait until the unit is cool.
4. Do not install where the marked operating temperatures (T-Code) exceed the ignition temperature of the hazardous atmosphere.
5. Do not operate in ambient temperatures above those indicated on the rating labels.
6. Keep tightly closed when in operation.
7. Do not use outdoors.
8. Do not mount near gas or electric heaters.
9. Use caution when handling batteries. Battery acid can cause burns to the skin and eyes. If acid is spilled on the skin or eyes, flush acid with fresh water and contact a physician immediately. Avoid possible shorting.
10. Equipment should be mounted in locations and at heights where it will not readily be subjected to tampering by unauthorized personnel.
11. The use of accessory equipment not recommended by the manufacturer may cause an unsafe condition.
12. Do not use this equipment for other than intended use.
13. Servicing of this equipment should be performed by qualified service personnel.

SAVE THESE INSTRUCTIONS

Installation Instructions

1. **Turn off unswitched AC power.**
 - a. Remove the unit cover (2). Disconnect the lamps from terminal block (see fig 3) and remove the electronic module (3). Three nuts secure the electronic module to the housing.
 - b. Determine which holes in the housing will be used for conduit. Support frame by two blocks of wood, maximum one inch apart. Strike knockouts with a hammer and screwdriver. Clear holes of burrs to allow proper installation of the fitting. Install conduit fitting rated for Class I Div 2, on the housing. For **Nexus** option, install the liquid tight fitting, provided with the unit to route the data cable.

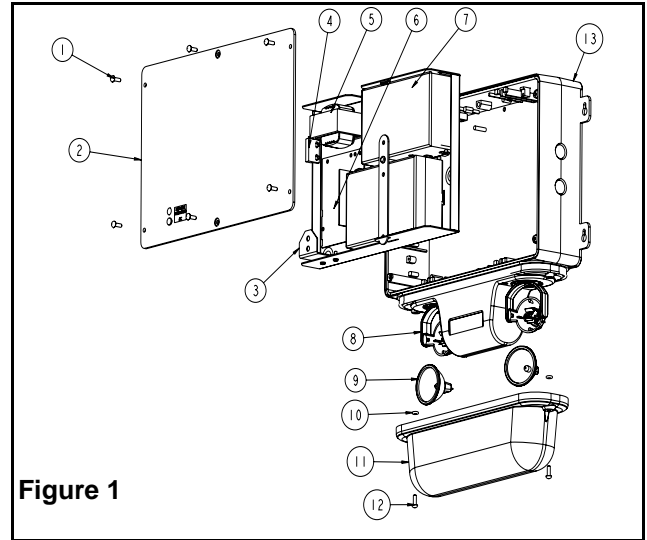

Figure 1

Part List

1. Tamper-proof screw
2. Unit covers
3. Electronic module
4. Magnetic test switch
5. Transformer
6. Charger board
7. Battery
8. Lamp holder
9. Lamp
10. O-ring
11. Lens
12. Tamper-proof screw
13. Housing

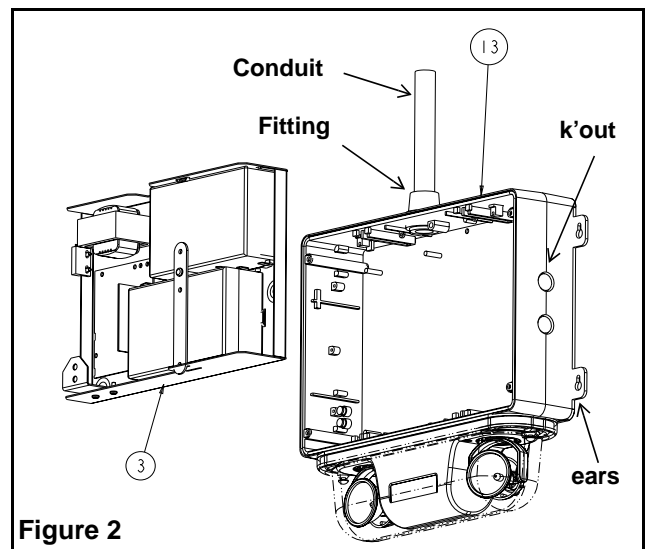

Figure 2

- c. Install the unit on the wall with 4 screws (not provided). Use the ears located on each side (see figure 2). Route unswitched AC circuit wires into the housing.
- d. Reinstall the electronic module inside the housing using the three nuts.

2. ELECTRICAL CONNECTIONS

Auto-diagnostic models (refer to figure 3.):

- a. Connect transformer primary wires to AC wires from building: white wire with neutral; black (120Vac) or red (347Vac) to line voltage. Unused primary wire must be insulated to prevent shorting. Connect green wire to the ground.
- b. Reconnect the lamps on terminal blocks (L1+/L1-).
- c. For units with remote capacity, connect the remote heads DC+ to L1+ and DC- to L1-.
- d. Connect the battery to the charger board.

Nexus models:

See Nexus addendum for the details on electrical connection.

3. Lamps adjustment:

- a. To access the lamps, remove the lens. Remove the lamps protectors. Adjust the lamps in appropriate position. Put the lens back in place.

4. Put the unit cover back in place. Make sure the unit is tightly closed.

5. Energize AC.

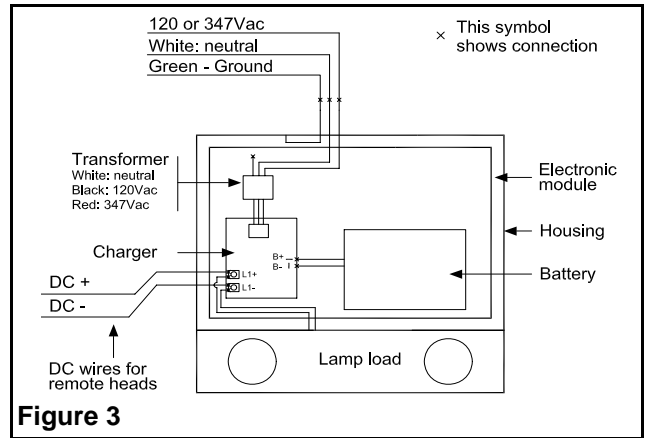

Figure 3

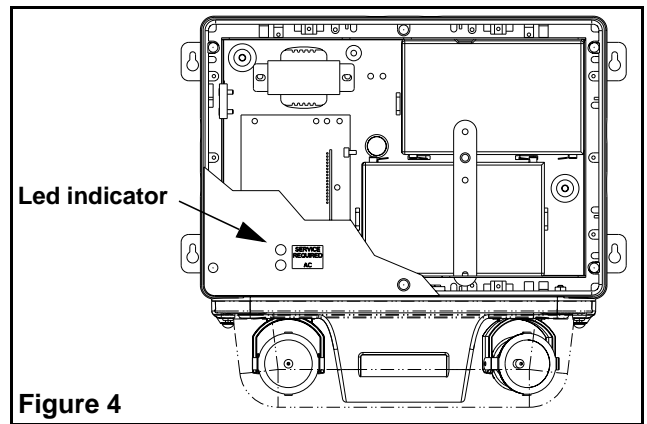

Figure 4

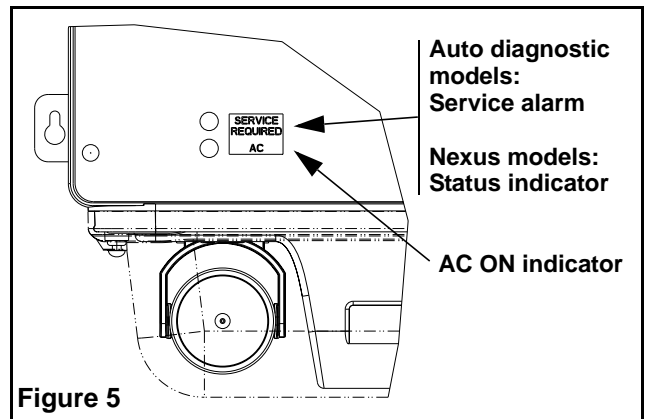

Figure 5

Manual Testing

Operate the magnetic “test switch” by holding the provided magnet where indicated on the side of the housing. This will initiate a one minute test. The DC lamps will illuminate for approximately one minute, then the unit will automatically return to stand by mode. Test can be cancelled by holding the magnet near the test switch again.

Automatic Testing

The unit will perform an automatic self-test of 1 minute every month, 10 minutes every 6 month and a 30 minutes self-test once a year.

Automatic Diagnostics

There are five diagnostic indicators: one external and four internal. Unit must be opened to gain access to internal indicators.

External: Service alarm, “Service Required”. The LED will turn-on if any alarm condition is detected (see fig. 4 & 5).

Internal: Battery Failure, Battery Disconnect, Charger Failure & Lamp Failure. Steady ON if alarm condition exists (See fig. 11).

Normal operation, No fault — “Service Required” is OFF.

Faulty operation — “Service Required” is ON.
(see AD charger owner manual for more details)

Nexus models

Nexus models use two local indicators. One is a green LED for AC pilot lamp. The other is a bicolor LED (Service) which identifies and displays the Nexus status. See Nexus addendum for details.

AD – Owner’s manual

Advanced Diagnostic Flash Memory Charger Board

1. Installer

This manual must be turned over to owner on completion of installation. **WARNING:** Please RESET the system whenever you add or change lamp load. (refer to section 2.2)

IMPORTANT SAFEGUARDS

When using electrical equipment, basic safety precautions should always be followed including the following:

READ AND FOLLOW ALL SAFETY INSTRUCTIONS

1. Do not mount near gas or electric heaters.
2. Use caution when handling batteries. Avoid possible shorting.
3. Equipment should be mounted in locations and at heights where it will not readily be subjected to tampering by unauthorized personnel.
4. The use of accessory equipment not recommended by the manufacturer may cause an unsafe condition.
5. Caution: If optional Halogen cycle lamp(s), symbol (H—), are used in this equipment, to avoid shattering: do not operate lamp in excess of rated voltage, protect lamp against abrasion and scratches and against liquids when lamp is operating, dispose of lamp with care.
6. Halogen cycle lamps operate at high temperatures. Do not store or place flammable materials near lamp.
7. Do not use this equipment for other than intended use.
8. All servicing should be performed by qualified service personnel.

SAVE THESE INSTRUCTIONS

2. Operation

The diagnostic/charger is a fully self-contained, fully automatic microcontroller based system.

The use of a high performance, 8 bit microcontroller enables us to provide the customer with one of the best charger/ diagnostic systems on the market. All operations are automatic and the installation is no more complicated than the procedure for a standard unit. When the installation is completed and the unit is powered, the system is automatically functional. There is no need to have the AC present at this time, only the battery needs to be connected. The unit goes directly in lockout mode and waits for AC to be restored.

The advanced diagnostic design is also based on field proven features that are well known for their high quality and reliability, such as the «PULSE PLUS» temperature compensated charger and the high quality sealed lead, lead-calcium, and NiCad batteries.

2.1 Standard features

2.1.1 General

High performance 8-bit microcontroller (MCU)
Lockout mode
Monthly and annual test sequence
Transfer delay

2.1.2 Charger

120/277 volts 60 Hz input standard
(120/347 in Canada)
Pulse charger under MCU control
Temperature compensated
Charger «ON» indicator lamp
AC «ON» pilot lamp

2.1.3 Transfer

Solid-State switching
Automatic and instantaneous
Low voltage battery disconnect
Fused output circuit
Brownout detection
Lockout

2.1.4 Diagnostic

Audible and non-audible version available
High efficiency red LED display
Battery failure
Battery disconnect
Charger failure
Lamp failure
Service alarm

2.2 System operation

The microcontroller provides decisional logic and output drivers for the monitoring and control of the battery, the charger, the lamp circuit, the LED strip, the transfer circuit, and all the alarm visual and audible indicators. Power line (AC) present indicator is also provided.

When an alarm is initiated, the audible warning, if enabled, is energized and the indicator associated with the fault is illuminated continuously. Alarms are acknowledged by hold the provided magnet near the magnetic “test switch”.less than one half second. This action turns off the audible alarm and changes the alarm indicator status from continuous to intermittent (flashing). The Service Alarm can only be restored by correcting the fault or by a system re-initialization.

Re-setting the microcontroller is accomplished by removing all power sources, battery and AC power.

To activate the transfer, hold the provided magnet near the magnetic “test switch”. The DC lamps will illuminate for approximately one minute, then the unit will automatically return to stand-by mode. The transfer can also be initiated by holding down the test

button located on the board. The transfer can also be cancelled: hold the magnet near the switch or hold down the test button another time.

During a prolonged power outage, alarm status and lamp circuit data are memorized. When power is restored, all functions and alarm conditions resume operation in the same way they were before the power failure.

2.2.1 Charger

The charging circuit is a hysteresis type for lead-calcium batteries and 2-level trickle type for Ni-cad batteries.

2.2.1.1 Charger monitoring

The «CHARGER FAILURE» indicator is illuminated if the charging current does not fall within limits corresponding to the charger command state. The charger circuit parameters are pre-defined in the software and correspond to the battery type.

2.2.1.2 Battery monitoring (charger output)

2.2.1.2.1 Open battery circuit

The «BATTERY DISCONNECT» indicator is illuminated when any portion of the battery wiring has become open.

2.2.1.2.2 Battery failure

This is a multi-function indicator related to battery condition. This indicator will be illuminated when a wrong battery (ex: 6V battery on a 12V system or vice versa) or a completely depleted battery (battery voltage less than 65% of nominal) is connected to the circuit – Allow 24 hours recharging if the battery voltage is between 25% and 65% of nominal – it will also be illuminated if the battery has failed a timed or forced test (reached LVD level before the end of the test).

In the case of incorrect battery, the circuit will disable the charge current.

2.2.2 Lamp (incandescent only) and LEDs strip (combo unit only) Testing

Load (incandescent lamps and own LEDs strip) sampling and testing takes place only with a relatively charged battery, that is when the «CHARGER ON» LED is off for lead type battery and after 72 hours recharging or initial charging for NiCad batteries. When the unit is in test mode for the first time after installation, current samples, through the filament are stored and used as a reference for each subsequent test. The lamps are re-sampled annually if a lamp failure was not detected.

2.2.3 Transfer module

The transfer module consists mainly of a power relay. The transfer relay is activated by the MCU when there is a power failure, a brown-out condition or the test switch has been activated. When a transfer is initiated (brown-out, manual test or auto-test), and the system fails to energize the lamp circuits, a system failure is detected and the «Service Alarm» indicator is illuminated.

3. Features

3.1 Automatic unit test (30-day test)

Every 30 days, while in charging mode, the sequence generator will generate a command to energize the transfer relay on the emergency lighting circuit for a certain duration.

The monthly test duration is one minute except for the 6th and the 12th month (see the table below). During the test period the charger is disabled and the charger monitoring functions are suspended.

Time period	US	Canada
monthly	one minute	one minute
6 th month	30 minutes	10 minutes
12 th month	90 minutes	30 minutes

Figure 1

If the battery fails to complete the discharge test, the «BATTERY FAILURE» indicator will be illuminated and the test aborted.

3.2 Transfer time delay (TD)

The Time Delay function (TD) is recommended when the battery unit is installed in areas normally illuminated by high-intensity discharge (HID) lamps, like: metal halide or high-pressure sodium lamps.

When enabled, the Standard Time Delay function maintains the emergency lights «ON» for 15 minutes after the AC main power is restored.

The Time Delay Function can be enabled or disabled in the field with the following procedure (see fig. 2):

- Make sure that the battery and the AC main power are both disconnected.
- Set the jumper JP7 as follows:

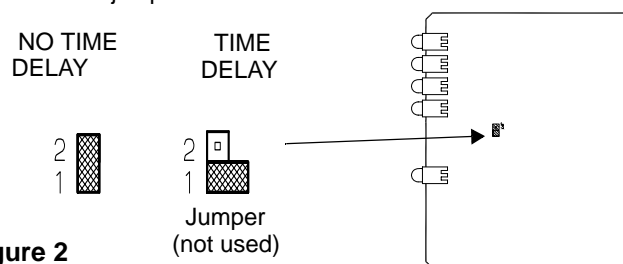

Figure 2

- Continue with the standard installation

3.2.1 Time delay duration

On request, the duration of the time delay can be set in the factory to another value: 5, 10, 15, 20 minutes. For ordering details, check the product catalogue.

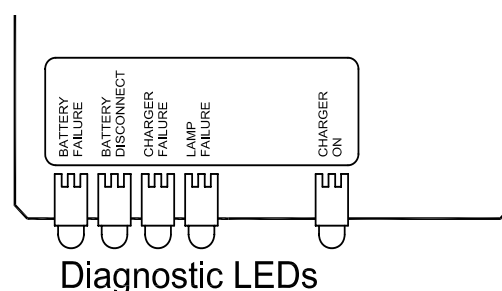

Figure 3

4. Equipment test display

Four high efficiency red LEDs for alarms located on the PCB (Indicates the failure diagnostic together with the Service Alarms) (see Figure 3). One red LED for SERVICE ALARM «on» and one green LED for AC «on» are located on the unit.

4.1 Battery failure

When illuminated with Service Alarm indicator: Indicates a battery failure or incorrect battery voltage.

Action required: Replace battery

4.2 Battery disconnect

When illuminated with Service Alarm indicator: Indicates that there is no battery connected to the charger.

Action required: Connect the battery. Check terminals.

4.3 Charger failure

When illuminated with Service Alarm indicator: Indicates that there is a problem with the charger circuit.

Action required: Have the unit serviced.

4.4 Lamp failure

When illuminated with Service Alarm indicator: Indicates that there is one or more lamps defective. Flashing when loosing 50% or more LEDs.

Action required: Replace defective lamp(s), or LEDs strip.

4.5 Service alarm

When illuminated alone: indicates a malfunction of the transfer circuit.

Action required: Check the lamp circuit (are the lamps connected?), the fuse, replace if necessary.

4.6 AC ON (green)

Illuminated when line voltage is present.

4.7 Charger ON (Yellow)

Depending on the type of battery used and the charger level of the battery, the yellow LED may light in different ways:

Continuously ON: The battery is in full charge mode.

Flashing at a rate of one flash per second or less: Lead acid battery at end of charge.

Flashing continuously, approximately 10 flashes per second: NiCad or NiMH battery in trickle charge.

4.8 Test button

To activate the transfer, hold the provided magnet near the magnetic “test switch”. It will initiate a 1 minute test.

The test can also be cancelled by holding the magnet near the switch.

5. Electrical specifications

Power requirements

Standard:

120/277V 60Hz in US

120/347V 60Hz in Canada

Output: Fused output circuit

One lamp circuit, fused, 15 Amps

Transfer

Dust-tight relay automatically and instantaneously energizes lamp load upon failure of AC supply.

Lamp Failure resolution

10% of the nominal rated power or minimum 5 Watts, whichever is lighter.

Exit sign LED failure resolution (only for mini-system/ combo units)

Loss of 50% or more of LEDs (as per UL 924).

LVD

Low voltage battery disconnect automatically shuts down lamp load and circuitry when battery reaches approximately 87% of nominal battery voltage preventing deep discharge and permanent damage of the battery.

Lockout

Labor saving feature that automatically connects battery only after the AC circuit is activated. This feature allows the installer to connect the battery prior to having the AC circuit activated.

Brownout

This feature initiates a transfer when the input line voltage dips below 70-80% of nominal voltage (power loss).

Charger

The charger is current limited, temperature compensated and short-circuit proof. The equipment is capable of full recharge in compliance with Underwriters Laboratories Std. 924 specifications, and CSA C22.2 no. 141.

Controls

One external test switch.

Voltage drop protection

When remote fixtures and exit signs are connected to emergency lighting units of less than 50 volts, circuit runs must be sufficient size to maintain a proper operating voltage to all lamps. The maximum allowable voltage drop should not exceed 5%. Proper wire size can be selected from the following table (see fig. 4) or by use of the following formula

$$CM = \frac{22 \times W \times L}{.05 \times E^2}$$

CM = Wire size in circular mills

W = Emergency load in watts

L = Length of circuit in feet

E = Line Voltage

22 = Constant

.05 = Factor for max. allowable voltage drop