



LED Retrofit Kits

Project/Location:
Contractor:
Date:
Prepared by:

Convert high consumption incandescent and fluorescent lamps to energy efficient LED lamps

Converting existing exit signage from incandescent or fluorescent lamps to LED (light emitting diodes) lamps drastically reduces operating and maintenance costs for building owners and property managers.

As part of energy efficiency programs, some Canadian electric utilities are also actively promoting conversion to LED with incentive and rebate programs for installers and building owners/managers.

EMERGI-LITE offers four retrofit kit options:

- SNAP II Series
- SNAP III Model
- SNAP I Model
- Bulb I/II

Here are some of the benefits of using LED lamps in exit signs:

- Exceptional energy efficiency – reduces energy consumption by up to 90%
- Extremely long life – 10 to 25 years
- Important reduction in maintenance and energy costs
- Average payback is less than two years
- Retrofit kits are easy to install
- Improved visibility and reliability; ALINGAP technology

How much can I save?

The following is an example of the savings you can generate by simply installing an LED retrofit kit in an existing incandescent exit sign.

Payback Analysis

The Retrofit Kits Cost is:	\$70.00
Installation cost (per unit) for a retrofit kit is (Labour):	\$5.00
Wattage rating per incandescent lamp in existing fixture:	15W
Number of incandescent lamps per fixture:	2
Wattage rating of Emergi-lite SNAPII-UN retrofit kit:	1.7W
My existing incandescent exit lamps last for:	4 Months
My replacement labour cost is:	\$25.00 / Hour
Estimate lamp replacement time per exit:	20 Minutes
The current material cost for each exit sign lamp is:	\$1.00 / Lamp
My current energy cost is:	\$0.060 / \$ Per kWh
The PAYBACK FOR YOUR INSTALLATION IS:	1.06 Year
THE ANNUAL RETURN ON INVESTMENT IS:	94.50 %
THE ANNUAL SAVING IS:	\$70.87

For more information, please do not hesitate to contact your sales representative.

Project/Location:

Contractor:

Date:

Prepared by:

LED Retrofit Kits



Dimensions

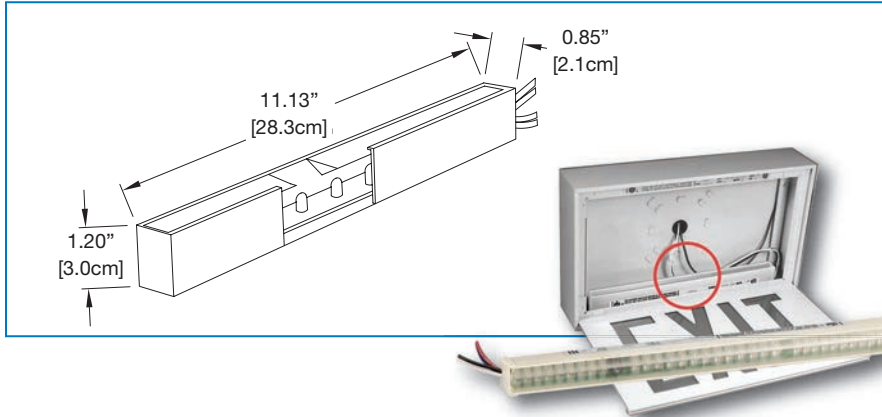

SNAP II Series Features

- Quick and easy to install
- Long-life, energy-efficient red ALINGAP LED technology
- Module features two independent circuits – one for AC input; one for DC input
- Universal AC input: 120/277/347Vac; universal two-wire DC input: 6 to 24Vdc
- Power consumption of 1.1W per module
- 10 year limited warranty

Ordering Information

Model	Brightness	Voltage
SNAP II= hardwire retro-fit kit 11.0" (28cm) long SNAP IIB= hardwire retro-fit kit 9.5" (24cm) long*	Blank= standard	-UN= 120/347vac, 6, 12, 24vdc -U36= 120/277/347vac-36vdc -U48= 120/277/347vac-48vdc -U120= 120/347vac-120vdc -120V-1H2= 120vac-120vdc-2wires

*Available in UN voltage only.

EXAMPLE: SNAPII-UN

Power Consumption

Model	AC Specs		DC Specs	
SNAP II	120/277/347Vac	1.1W	6 to 24Vdc	1.3W

Dimensions

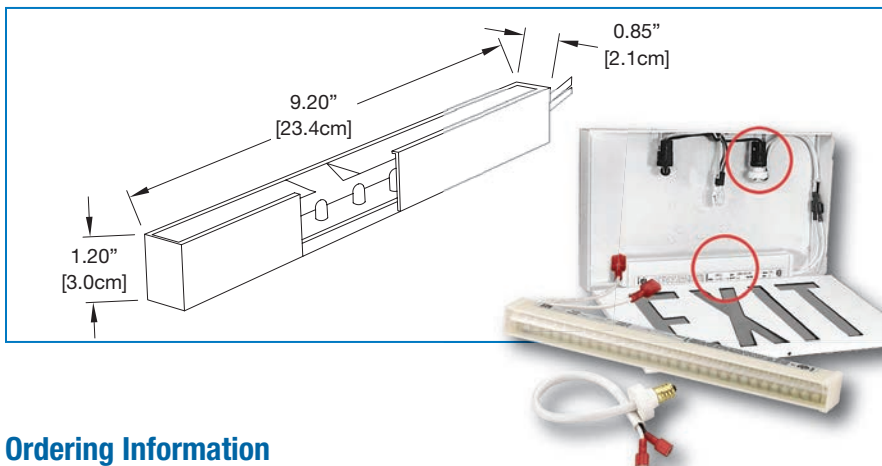

SNAP III Series Features

- Easiest to install in its class
- Compact size makes it ideal for virtually all exit signs
- Can be retrofitted directly on fluorescent ballast
- Long-life, energy-efficient red ALINGAP LED technology
- Available with AC adaptor for all type of lamp sockets
- 10 year limited warranty

Ordering Information

Model	Base
SNAP III = for standard applications	-C = candelabra -I = intermediate -M = medium -B = bayonet -F = G23 compact fluorescent -UN = complete set of bases (excludes "F" base) -H = 120Vac (hardwire) -8H = 240Vac (hardwire) -2H = 277Vac (hardwire) -3H = 347Vac (hardwire)

EXAMPLE: SNAPIII-C

Power Consumption

Model	AC Specs		DC Specs	
SNAP III	120Vac; 347 to 86Vac	1.7W	N/A	N/A

LED Retrofit Kits



Project/Location: _____

Contractor: _____

Date: _____

Prepared by: _____

SNAP I Series

Features

- Easiest to install in its class
- Compact size makes it ideal for virtually all exit signs
- Can be retrofitted directly on fluorescent ballast
- Suitable for all AC line applications including exit signs equipped with in-line diodes
- Available in high brightness or ultra high-brightness LEDs
- Long-life, energy-efficient ALINGAP LED technology

Dimensions

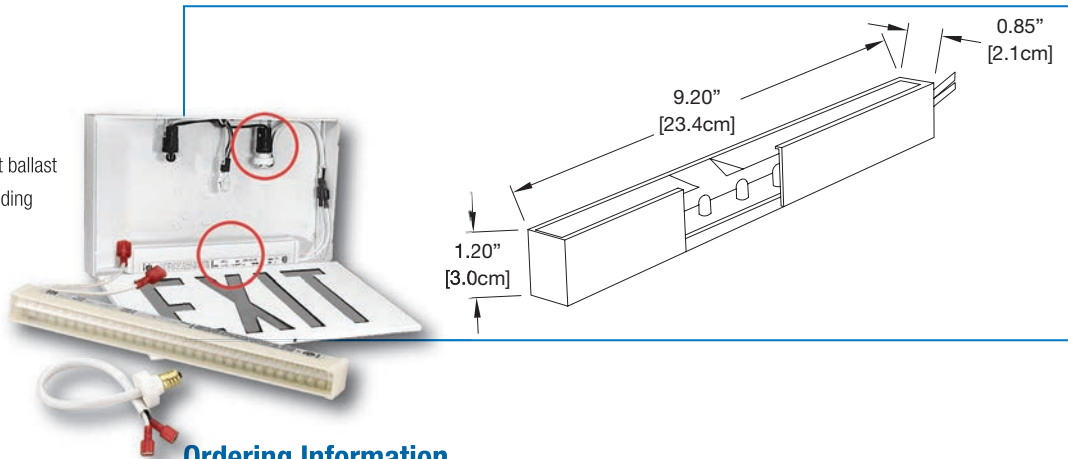

Power Consumption

Model	AC Specs		DC Specs	
	Voltage	Power	Current	Power
SNAP I	120Vac with in-line diodes	2.8W	N/A	N/A

Ordering Information

Model	Base
SNAP I = with or without in-line diodes	<ul style="list-style-type: none"> -C = candelabra -I = intermediate -M = medium -B = bayonet -F = G23 compact fluorescent -UN = complete set of bases (excludes "F" base) -H = 120Vac (hardwire) -8H = 240Vac (hardwire) -2H = 277Vac (hardwire) -3H = 347Vac (hardwire)

EXAMPLE: SNAP I-C

Bulb Series

Features

- Quick and easy to install
- Available with wide range of lamp bases for quick lamp to lamp replacement
- Available in high brightness or ultra high-brightness LEDs
- 120Vac or 120Vac with in-line diode
- Long-life, energy-efficient ALINGAP LED technology

Dimensions

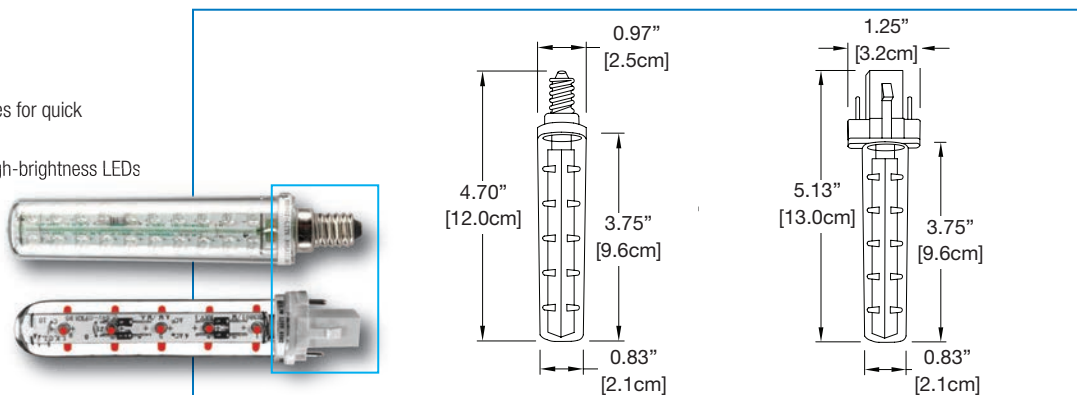

Power Consumption

Model	AC Specs		DC Specs	
	Voltage	Power	Voltage	Power
BULB I	120Vac	0.90	N/A	N/A
BULB II	120Vac	2.60W	120Vdc	2.4W

Ordering Information

Model	Base
BULB I/HB = Standard version BULB II/HB = to be used with or without inline diodes (2.5 watts)	<ul style="list-style-type: none"> -C = candelabra -I = intermediate -M = medium -B = bayonet -F = G23 compact fluorescent

EXAMPLE: BULB I-C