

Project/Location: \_\_\_\_\_

Contractor: \_\_\_\_\_

Date: \_\_\_\_\_

Prepared by: \_\_\_\_\_

# JMLA Series

## 6 and 12 Volts Decorative Battery Units



### Typical Specification

Supply and install the Emergi-Lite **JMLA Series** battery units. The battery unit shall come complete with two MR16 emergency light heads.

The unit shall be rated for dual input voltage: 120 / 347 V, 60 Hz. The unit shall provide the nominal load during at least 30 minutes up to 87.5% of the nominal voltage of the battery. The charger shall be factory set with a charging voltage tolerance of  $\pm 1\%$  to enable a longer battery life.

The emergency light heads shall be fully adjustable and protected by a clear cover, made of shock resistant polycarbonate. The protective cover shall be designed to facilitate the lamp replacement. The heads shall be installed at the bottom of the unit, providing an illumination in any direction. The emergency light heads shall require no tools for adjusting or aiming. The metal cabinet shall be made of steel with anti-corrosion undercoating.

The unit equipped with the auto diagnostic micro-controller board shall self-test 1 minute every 30 days, 10 minutes the 6th month and 30 minutes every 12 months. The unit shall be supplied with a test switch and diagnostic LED indicator lights to continuously monitor the status of the unit: Battery Failure, Battery Disconnect, Charger Failure, Lamp Failure, Service Alarm, main voltage AC "ON", Charger High Rate.

The unit shall be CSA Certified to C22.2 no. 141.

The unit shall be Emergi-Lite model: \_\_\_\_\_.

### Dimensions

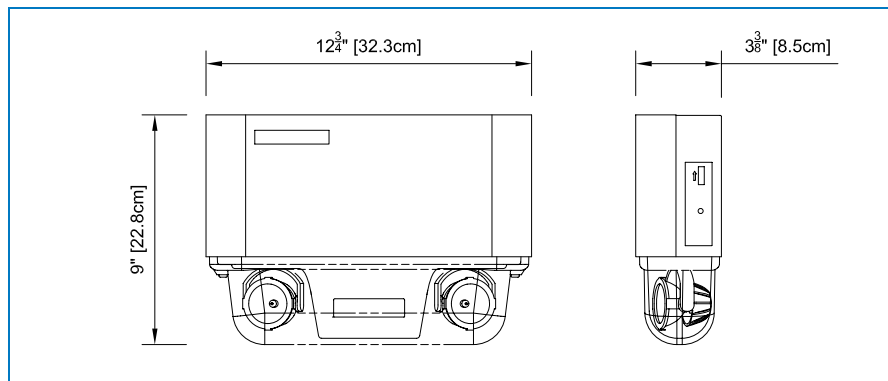

### Features

- Rugged steel cabinet with corrosion-resistant undercoating
- Removable front panel on cabinet provides easy access and allows unit to be mounted at ceiling height
- Solid-state pulse-type charger – current-limited, temperature-compensated, short-circuit proof and reverse-polarity protected
- Unit comes standard with electronic lockout and brownout circuits
- Sealed dust-proof transfer relay, test switch and LED indicator light(s)
- Long-life, maintenance-free lead acid battery
- NEXUS® compatible



### Wire Guards

460.0080-E	Wall Mount
------------	------------

### Replacement Lamps

Ordering Code	Type	Voltage-Wattage
580.0074-E	MR16 (EF40M6W)	6V - 6W
580.0079-E	MR16 (EF40M10W)	6V - 10W
580.0080-E	MR16 (EF40M12W)	12V - 12W
580.0068-E	MR16 (EF40M20W)	12V - 20W

### Power Consumption and Unit Rating

Model Number	AC Specs		Emergency power available for lamps				
			30min	1h00	1h30	2h00	4h00
06JMLA27	120 / 347Vac	0.06 / 0.02 Amp	27	15	11	9	-
06JMLA44		0.18 / 0.06 Amp	44	26	18	15	7
06JMLA72		0.19 / 0.07 Amp	72	42	30	24	12
12JMLA44		0.31 / 0.10 Amp	44	26	18	15	7
12JMLA72		0.31 / 0.10 Amp	72	42	30	24	12

### Ordering Information

Series	Capacity	Colour	Voltage	Options	Number of Heads	Head Style/Wattage
<b>06JMLA =</b> 6 volts	<b>27=</b> 27 watts* <b>44=</b> 44 watts <b>72=</b> 72 watts	<b>Blank=</b> factory white <b>BK=</b> black	<b>Blank =</b> 120Vac input with line cord installed <b>-2 =</b> 277Vac input <b>-8 =</b> 240Vac input*	<b>Blank=</b> no options <b>CT=</b> cab-tire <b>LW=</b> cab-tire + twist lock plug <b>U=</b> auto diagnostic <b>UN=</b> auto diagnostic, non-audible <b>NEX=</b> Nexus system interface* <b>LC=</b> linecord (120V) * Consult your sales representative - not available in 6V-72W. ** 6V-72W available in ESL series only.	<b>/2 =</b> two heads	<b>MJ =</b> mini halogen, 6V - 6 watt, MR16 <b>MJ =</b> mini halogen, 6V - 10 watt, MR16 <b>MK =</b> mini halogen, 12V - 12 watt, MR16 <b>MW =</b> mini halogen, high output, 12V - 20 watt, MR16
<b>12JMLA =</b> 12 volts	<b>44=</b> 44 watts <b>72=</b> 72 watts					
	* Not available in 12V.		* Not CSA Approved.			

EXAMPLE: 12JMLA44UN/2MW