



Survive-All NXM Series

NEMA-4X Certified Battery Unit

Project/Location: _____

Contractor: _____

Date: _____

Prepared by: _____

Features

Standard

- Fully gasketed cast aluminum back plate with clear polycarbonate cover – NEMA-4X Certified
- NSF Certified for food processing plants
- Comes standard with non-audible advanced diagnostic charger board, 10 minute time delay and lamp disconnect
- Audible warning and time delay functions can be enabled or disabled during installation
- Micro-controller diagnostic system tests, detects and indicates battery, charger circuitry or MR16 lamp failures
- Non intrusive magnetic test switch
- Long-life, maintenance free sealed lead acid battery
- 1/2" rigid conduit entry on top and back
- Can be installed on 4-inch junction boxes
- Comes standard with tamper-proof screws and bit
- Cold weather option (-40°C)
- Also available as a remote fixture. Please refer to "Remote Fixture" section, Survive-All EF39 Series.

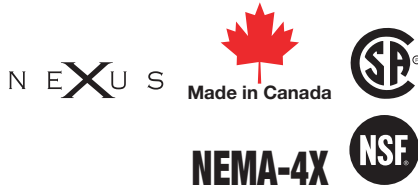

Typical Specification

Supply and install the Emergi-lite NEMA-4X Certified **Survive-All NXM Series** battery unit.

Specifically designed for high abuse areas, wet locations, and cold weather (CW option -40°C), the housing shall be fully gasketed with a cast aluminum back plate and clear heavy-duty UV resistant polycarbonate cover. The heads shall be fully adjustable without tools and the lamps shall be high efficiency halogen MR16. The standard unit shall be equipped with tamper-proof screws and bits.

The Emergi-Lite auto diagnostic Micro-controller charger board shall supply the rated load for a minimum of 30 minutes to 87.5% of the rated battery voltage. The charger incorporates lockout and brownout circuits, and low voltage disconnection. It protects the unit from over-current, short-circuit, and reverse polarity. The unit shall be rated 120/347V, 60Hz.

This unit shall self-test for 1 minute every 30 days, 10 minutes on the 6th month and 30 minutes every 12 months. The unit shall be furnished with a non-intrusive magnetic test switch. A "Service Required" lamp shall be located near the test switch and flash when a fault is detected. A four-LED diagnostic display shall be located inside the equipment and shall identify the source of failure (battery, charger, circuitry, or lamps).

The unit shall be CSA C22.2 No.141. certified. It shall also be NSF Certified for use in food processing plants.

The unit shall be Emergi-Lite model: _____.

Dimensions

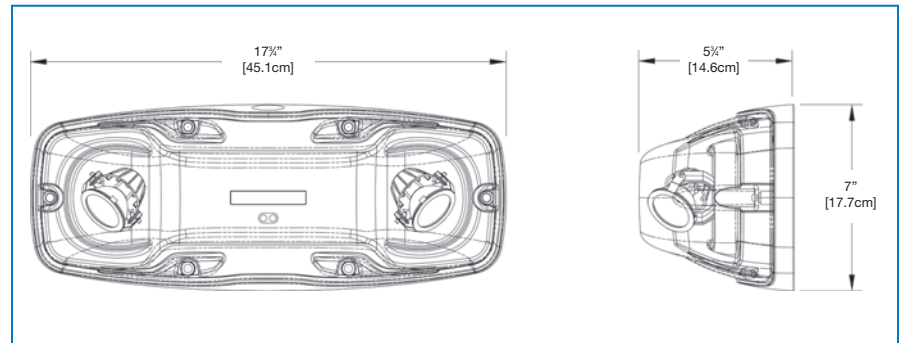

Wire Guards

460.0031-E Wall Mount

Replacement Lamps

Model	Specifications
580.0074-E	M6W, MR16, 6V - 6W, flood
580.0079-E	M10W, MR16, 6V - 10W, flood
580.0080-E	M12W, MR16, 12V - 12W, flood
580.0068-E	MH20W, MR16, 12V - 20W
580.0093-E	L, MR16, 12V - 5W

Power Consumption and Unit Rating

Model Number	AC Specs	Wattage Capacity					
		30min	1h00	1h30	2h00	4h00	
06NXM36	120 / 347Vac	0.15 / 0.05 Amp	36W	21	15	12	6
12NXM78		0.25 / 0.10 Amp	72	42	30	24	12
12NXM108		0.25 / 0.10 Amp	108	63	45	36	18
Cold Temperature 36W		0.45 / 0.20 Amp	36	*	-	-	-
Cold Temperature 72 / 108W	20 Vac	0.85 Amp	72/108	*	-	-	-

*Note: capacity depends on the ambient temperature

Ordering Information

Series	Colour	Capacity	Voltage	Options	Number of Heads	Lamp
06NXM= 6 volts 12NXM= 12 volts	Blank = factory white B = black G = grey	36= 6V-36W 72= 12V-72W 108= 120V-108W	Blank= 120/347vac 2= 277vac	Blank= no options CW1= cold weather 120vac CW3= cold weather 347vac* NEX= nexus system interface** PMK= universal bracket (sold separately) * Available in 6V only. ** Not all options available with NEXUS. Consult your sales representative.	/2 = two heads	L = 12V-5W LED M1 = mini halogen, 6V - 6 watt, MR16 MJ = mini halogen, 6V - 10 watt, MR16 MK = mini halogen, 12V - 12 watt, MR16 MW = mini halogen, 12V - 20 watt, MR16

EXAMPLE: 06NXMW36/2M1