



# Retract-a-Lite Series

## Fully Concealed Emergency Lighting System

Project/Location: \_\_\_\_\_

Contractor: \_\_\_\_\_

Date: \_\_\_\_\_

Prepared by: \_\_\_\_\_

The **Retract-a-Lite Series** by Emergi-Lite goes virtually undetected, blending into any environment. When AC fails and the lights go out, the Retract-a-Lite emerges, illuminating the path to safety.

### Features

- Door flips 180° when AC fails
- Fully automatic operation – brown-out sensitive transfer circuit automatically goes to emergency lighting mode and, when the power is restored or at the end of battery discharge, the motor turns the door back in its original closed mode.
- Impressive Charger – fast and automatic recharge, micro-controller driven, temperature compensated, high-precision
- Customized finish – unit sold in white but can be painted or wallpapered on site to match existing décor
- Heavy-duty back-box – made of heavy-duty, galvanized steel
- High Performance Lighting– includes two MR16 halogen lamps; power range from 2x12W up to 2x50W
- Also available as a remote fixture; see Remote Fixtures section of this catalogue
- Patent-pending design



### Typical Specification

Supply and install an **Emergi-Lite Series Retract-a-Lite** fixture as specified and as shown on the drawings. The unit shall be designed with a concealed back-box to be installed in wall or ceiling cavity, including T-bar suspended ceilings. Bar hanger brackets shall be provided with the self-powered unit.

The battery unit shall consist of a metal back box containing the batteries, the lamp assembly and a charging circuitry. The back box shall be constructed of heavy-duty galvanized steel. The unit components: battery assembly, charger circuitry and lamp assembly shall have a modular design and come standard with quick connect plugs for easy installation in the back box.

The unit equipment shall be completely concealed in the wall or ceiling during normal power conditions. Upon a power failure the unit will expose the emergency heads by rotating its door 180° and then power the lamps. At the restoration of the AC power or at the end of the battery discharge, the lamps will turn off and the unit will retract the heads in the wall (ceiling) by rotating the door by 180°. Under normal conditions, the only visible parts of the unit shall be the flat door and trim plate, coated with a high-quality off-white finish that can be customized on site with paint or other suitable wall covering. The light source shall be 12V MR16 halogen lamps of specified wattage and light output. The unit shall supply the rated load for a minimum of 30 minutes or until the battery is discharged to 87½% of its nominal voltage (whichever duration is longer). The charger circuitry shall utilize a micro-controller IC that samples the battery in relation to the ambient temperature, state of charge, and input voltage fluctuations. The charger shall be current limited, temperature compensated, short-circuit proof, and reverse-polarity protected. The circuit will charge in accordance with the CSA C22.2 – 141 requirements. The unit shall be furnished with a recessed, illuminated push button serving as test switch and status indicator light.

The unit will come complete with an auto diagnostic micro-controller circuitry that will ensure the equipment readiness and reliability by continuously monitoring critical functions of the unit. If a problem occurs, the pilot light located on the front of the battery unit, will change color from green to red and will flash indicating a fault. A detailed diagnostic legend shall be available on the door back side and shall provide fault identification (battery, charger circuitry, lamps) for the maintenance personnel. The auto diagnostic shall simulate a power loss for one minute monthly, 10 minutes every sixth months, and a 30-minute test every 12 months.

The equipment shall be Emergi-Lite model: \_\_\_\_\_.

### Replacement Lamps

Ordering Code	Type	Voltage-Wattage
580.0080-E	MR16 12W CVR FL	12V-12W
580.0075-E	MR16 20W CVR FL	12V-20W
580.0083-E	MR16 35W CVR FL	12V-35W
580.0076-E	MR16 50W CVR FL	12V-50W
580.0068-E*	MR16 IR 20W CVR FL	12V-20W
580.0090-E*	MR16 IR 35W CVR FL	12V-35W
580.0089-E*	MR16 IR 50W CVR FL	12V-50W

\*High-output (H)

### Dimensions

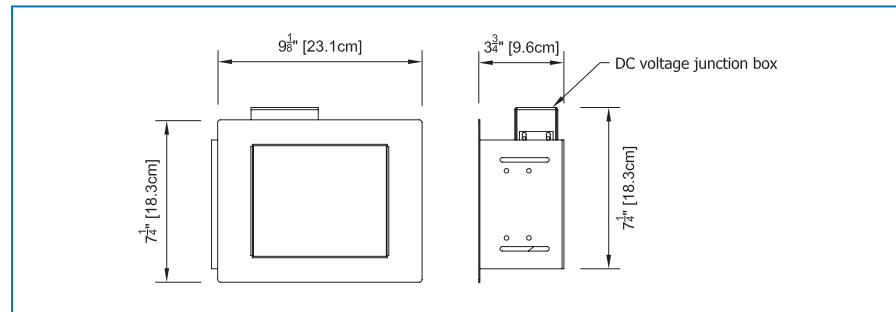

### Power Consumption and Unit Rating

Model Number	AC Specs	Emergency power available for lamps				
		30min	1h00	1h30	2h00	4h00
RTL75	120 / 347Vac 0.25 / 0.09 Amp	75W	40W	30W	24W	15W
RTL150		150W	80W	60W	48W	30W

### Ordering Information

Series	Powerpack	Options	Number of Heads	Head Style and Wattage
RTL	75= 12V, 75 W Lead-acid 150= 12V, 150 W Lead-acid	Blank= 120/347Vac -2= 120/277Vac	/12= 2x 12 watts MR16 /20= 2x 20 watts MR16 /35= 2x 35 watts MR16 /50= 2x 50 watts MR16 /20H= 2x 20 watts MR16, High lumen output /35H= 2x 35 watts MR16, High lumen output /50H= 2x 50 watts MR16, High lumen output	U= auto diagnostics UN= auto diagnostics, non-audible D3= time delay 15 min

EXAMPLE: RTL150/35HU