

Project/Location: _____

Contractor: _____

Date: _____

Prepared by: _____

ESLNX Series

6, 12 and 24 volts, NEMA-4X rated



Typical Specification

Supply and install the **Emergi-Lite** NEMA-4X Rated **ESLNX** Series battery unit. Specifically designed for high abuse areas and wet locations, the fiberglass reinforced polyester housing shall be fully gasketed as well as the clear heavy-duty UV resistant polycarbonate lamp enclosure. The lamps shall be fully adjustable without tools and shall be high efficiency halogen MR16.

The **Emergi-Lite** Smart Diagnostic Micro controller board shall supply the rated load for a minimum of a 1/2 hour to 87.5% of the rated battery voltage. The unit shall be rated 120V or 347V, 60 Hz and be CSA listed. The unit shall have an output of _____ volts.

The charger shall be fully computer tested and its charge voltage factory set to $\pm 1\%$ tolerance. Chargers with field-adjusted potentiometers are not acceptable. A pulse-type charger shall be employed to promote long battery life and reduce the potential for grid corrosion. The charger shall provide a continuous high charge to recharge the battery, when the battery is at full capacity, the charger will shut-off. Periodically the charger shall provide a pulse of energy to keep the battery topped off. The Pulse charge shall be current limited and precisely regulated by a micro-processing circuit, which samples the battery in relation to its temperature, state or charge and input voltage fluctuations. The charger shall be current limited, temperature compensated, shortcircuit proof and reverse polarity protected. The unit shall be furnished with an electronic lockout circuit, which will connect the battery when the AC circuit is activated, and an electronic brownout circuit, which will activate the emergency lights when utility power dips below 75% of nominal voltage. A low voltage battery protection circuit shall be provided and will disconnect the battery from the fused output circuit at the end of discharge. The unit shall self-test for 1 minute every 30 days, 10 minutes on the 6th month and 30 minutes every 12 months. The unit shall be capable of full recharge in compliance with CSA specifications. The unit shall be furnished with sealed dust tight relay, a test switch and diagnostic LED indicator lights to continuously monitor the status of the unit: Battery Failure, Battery Disconnected, Charger Failure, Lamp Failure, Service Alarm, AC "ON", Charger High Rate.

The unit shall be **Emergi-Lite** model: _____.

Harsh environment emergency lighting units: The ESLNX Series battery units are specifically designed for use in industrial facilities where equipment is exposed to dust, water, oil or corrosive substances. NEMA-4X rated to protect circuitry from harmful dust or liquid sprays, sealed and gasketed unit made of fiberglass reinforced polyester.

Features

- Delivers great pathway illumination up to 70 feet, center to center (with M20 WH lamp)
- Fully gasketed fiberglass reinforced polyester housing - NEMA 4X rated
- Solid-state pulse-type charger – current-limited, temperature-compensated, short-circuit proof and reverse-polarity protected.
- Unit comes standard with electronic lockout and brownout circuits
- Sealed dust-proof transfer relay, test switch and LED indicator lights
- Long-life, maintenance-free sealed lead acid battery
- Standard 120/347Vac input voltage with line cord kit
- NEXUS® compatible (for more information on NEXUS®, please consult the factory)
- CSA C22.2 No. 141 certified

Dimensions

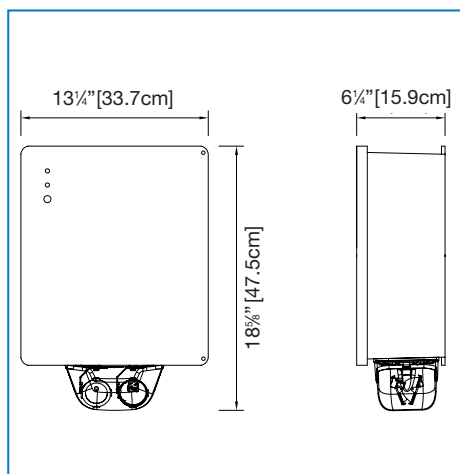

Wire Guards

460.0034-E Wall Mount

Power Consumption and Unit Rating

Model	AC Specs	Wattage Capacity					
		30 min.	1 hour	1h30	2 hours	4 hours	
06ESLNX36	120/347Vac	0.10/0.04 Amp	36	21	15	12	6
06ESLNX72		0.22/0.08 Amp	72	42	30	24	12
06ESLNX108		0.22/0.08 Amp	108	63	45	36	18
06ESLNX180		0.22/0.08 Amp	180	105	75	60	30
12ESLNX36	120/347Vac	0.09/0.03 Amp	36	21	15	12	6
12ESLNX72		0.15/0.06 Amp	72	42	30	24	12
12ESLNX100		0.34/0.12 Amp	100	58	42	33	17
12ESLNX144		0.40/0.14 Amp	144	84	60	48	24
12ESLNX200		0.41/0.14 Amp	200	117	83	67	33
12ESLNX250		0.41/0.14 Amp	220	120	90	72	36
24ESLNX144	120/347Vac	0.55/0.20 Amp	144	84	60	48	24
24ESLNX288		0.67/0.23 Amp	288	168	120	96	48
24ESLNX350		0.67/0.23 Amp	350	200	144	120	60



Ordering Information

Series	Housing	Capacity	A.C. Voltage	Options	# of Heads	Lamp Wattage
06ESL = 6 volts	NX = NEMA 4X	36 = 36 watts 72 = 72 watts 108 = 108 watts 180 = 180 watts	Blank = 120/347Vac input -2 = 277Vac input -3 = 347Vac input	A = ammeter D = time delay (programmable) D1 = time delay 5 min. D2 = time delay 10 min. D3 = time delay 15 min. D4 = time delay 20 min. D5 = time delay 30 min. L = line cord LW = Cabtire + Twist lock plug (120V only) NEX* = Nexus system (6, 12 and 24V) P = light activated test switch T = lamp disconnect TBC = d.c. terminal block U = auto diagnostic V = voltmeter X = remote test receiver H = heater & thermostat	/0 = no heads /1 = one head /2 = two heads	MI = 6V 6W MR16 MJ = 6V 10W MR16 MK = 12V 12W MR16 MA = 12V 20W MR16 MD = 24V 20W MR16 MS = 24V 12W MR16
12ESL = 12 volts	NX = NEMA 4X	36 = 36 watts 72 = 72 watts 100 = 100 watts 144 = 144 watts 200 = 200 watts 250 = 250 watts				
24ESL = 24 volts	NX = NEMA 4X	144 = 144 watts 288 = 288 watts 350 = 350 watts				

* Not all options available with Nexus. Please consult factory.

EXAMPLE: 24ESLPK350U/2Q20