

Project/Location: \_\_\_\_\_

Contractor: \_\_\_\_\_

Date: \_\_\_\_\_

Prepared by: \_\_\_\_\_

# Premier Series

## Compact Exit Sign



### Typical Specification

Supply and install the Emergi-Lite Premier exit sign. The standard equipment shall operate with a dual-voltage input of 120V/347Vac with less than 2.5 Watts of consumption and a universal two-wire DC input voltage from 6Vdc to 48Vdc at less than 2 Watts for single and double face signs. The exit shall be suitable for wall, end, or ceiling mount. The faceplate shall be constructed of a durable high impact thermoplastic. No screws are necessary to hold the faceplate or the back plate to the housing. The faceplates shall come standard with snap in/out chevrons. The frame shall consist of a one-piece factory white thermoplastic. The light source shall be light emitting diodes (LEDs). The LEDs shall provide illumination in normal and emergency operation and shall be mounted inside the exit housing. Red LED technology shall be ALINGAP. A LED-sensitive diffuser shall be mounted in front of the LEDs to provide the 6" high by 3/4" stroke letters with even illumination. The exit sign shall be certified CSA-C860.

The exit sign in a self-powered configuration shall be equipped with a sealed, maintenance-free Nickel-Cadmium battery. The equipment shall recharge the battery in 24 hours and stay illuminated at least 90 minutes upon AC failure. The self-powered model equipped with advanced diagnostic shall self-test by simulating a power failure for one minute every 30 days, 30 minutes every 60 days and 90 minutes every 360 days. A diagnostic circuit shall continuously monitor the performance of the battery, charger module and LED lamps. Upon failure detection the system shall display the error on the AC pilot lamp, which will change color from green to red and will flash with a specific code. The red light shall be steady-on in case of "Battery Disconnect"; it shall flash with one blink for "Battery failure", two blinks for "Charger failure" and four blinks for "LED lamp failure. A label with the diagnostic legend shall be visible next to the pilot light.

The exit sign shall be Emergi-Lite model: \_\_\_\_\_.

### Features

- High capacity battery unit
- Durable, injection-molded, thermoplastic housing
- Universal mounting - supplied standard with two stencil plates, red diffusing lens and backplate.
- Universal, field-selectable snap in/out chevrons
- Available for wall, end or ceiling mounting
- Energy efficient – consumes less than 3.5 watts
- Normal AC and emergency DC operation with dual AC input of 120V/347V and universal DC input of 6V to 48V
- Comes with the Emergi-Lite EZ2 canopy for quick and easy installation – see page 40 for more information



### Dimensions

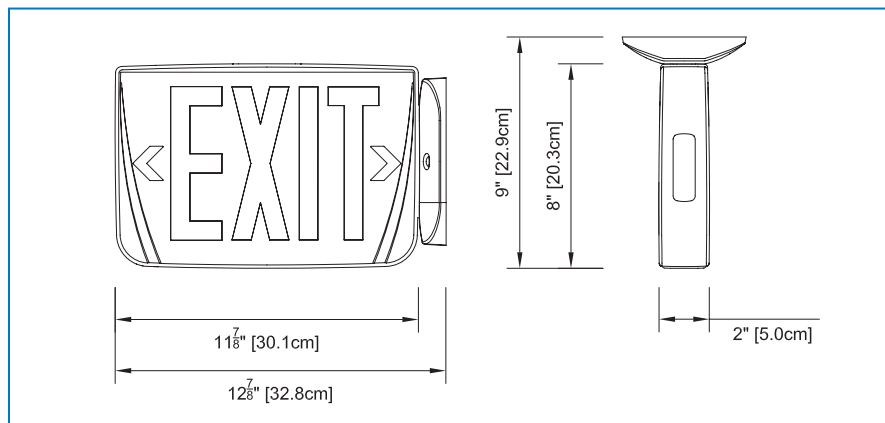

### Wire Guards

460.0079-E	Wall Mount
460.0027-E	End Mount
460.0028-E	Ceiling Mount

### Power Consumption

Model	AC Specs		DC Specs	
AC-Only	120 / 347Vac	Less than 2.5W	-	-
AC/DC- Remote	120 / 347Vac	Less than 2W	6 to 48Vdc	Less than 1.5W
Self-powered	120 / 347Vac	Less than 3.5W	NiCad battery	Min. 90 minutes
Self-powered with advanced diagnostic	120 / 347Vac	Less than 3W	NiCad battery	Min. 90 minutes

### Ordering Information

Series	Colour	Unit Capacity	Voltage	Legend Colour	Options
<b>PRE=</b> LED plastic universal exit sign	<b>W=</b> factory white <b>B=</b> black	<b>AC=</b> AC only <b>UD=</b> 120/277 or 120/347Vac & 6 to 48Vdc <b>IN=</b> self-powered NiCad <b>IDN=</b> self-powered with self diagnostics NiCad	<b>2=</b> 120/277Vac <b>3=</b> 120/347Vac	<b>R=</b> red <b>G=</b> green	<b>FA=</b> fire alarm activated flasher** <b>NEX=</b> NEXUS® system interface**  *AC, UD, or IDN models only **Consult your sales representative for options available with the NEXUS® system.

EXAMPLE: PREWAC2R