



# Literay Series

## Wall Mount Remote Head

Project/Location: \_\_\_\_\_

Contractor: \_\_\_\_\_

Date: \_\_\_\_\_

Prepared by: \_\_\_\_\_

### Features

- Compact wall sconce unit for indoor and outdoor use
- High impact resistant polycarbonate diffuser
- Corrosive resistant die-cast aluminum housing
- Vandal resistant
- Adjustable MR16 lamps

### Typical Specification

Wall mount unit shall be gasketed die-cast aluminum housing, impact resistant polycarbonate diffuser.

The lamps shall be in adjustable for aisle or area distribution.

Fixture shall be supplied with gasket and shall be suitable for installation on any four inch octagonal box.

The fixture shall be certified to CSA C22.2 No.250

The unit shall be Emergi-Lite model: \_\_\_\_\_.



### Dimensions

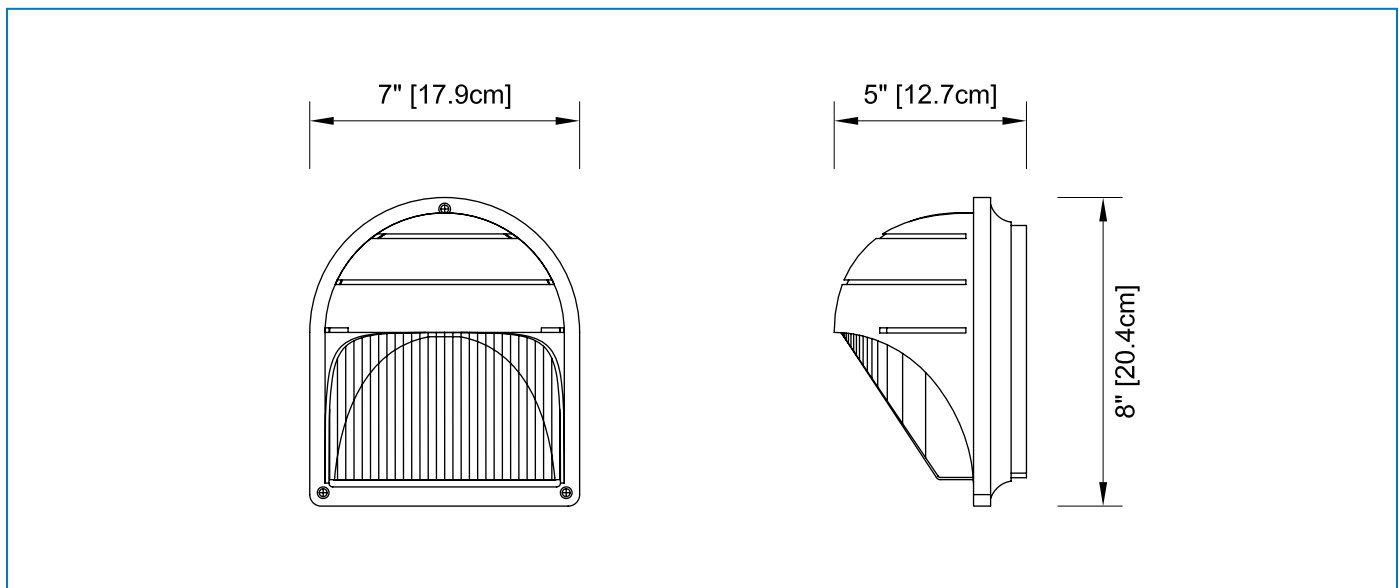

### Replacement Lamps

Model	Type	Voltage-Wattage
580.0079-E	MR16-Flood	6V - 10W
580.0080-E		12V - 12W
580.0068-E		12V - 20W
580.0077-E		24V - 12W
580.0070-E		24V - 20W

See the complete list page 91

### Ordering Information

Series	Lamp Type	Colour	Lamp Type and Wattage	Options
EF33= Exterior remote	<b>M</b> = MR16 <b>Blank</b> = (1) med. base socket only (max.60W) no lamp included	<b>Blank</b> = factory white <b>B</b> = black <b>DG</b> = dark grey	<b>Blank</b> =no lamps <b>-6V10W</b> = (2) 6V - 10 watts, MR16 <b>-12V12W</b> = (2) 12V - 12 watts, MR16 <b>-12V20W</b> = (2) 12V - 20 watts, MR16 <b>-24V12W</b> = (2) 24V - 12 watts, MR16 <b>-24V20W</b> = (2) 24V - 20 watts, MR16	<b>-VR</b> = vandal resistant screws <b>990.0119-E</b> = tamper proof bit*  *One bit needed per order.

EXAMPLE: EF33M-12V12W