



Thermoplastic Battery Unit

Emergency Lighting

IMPORTANT SAFEGUARDS

When using electrical equipment, basic safety precautions should always be followed including the following:

READ AND FOLLOW ALL SAFETY INSTRUCTIONS

1. Do not let power supply cords touch hot surfaces.
2. Do not mount near gas or electric heaters.
3. Use caution when handling batteries. Avoid possible shorting.
4. Equipment should be mounted in locations and at heights where it will not readily be subjected to tampering by unauthorized personnel.
5. The use of accessory equipment not recommended by the manufacturer may cause an unsafe condition.
6. Caution: If optional Halogen cycle lamp(s), symbol (H—), are used in this equipment, to avoid shattering: do not operate lamp in excess of rated voltage, protect lamp against abrasion and scratches and against liquids when lamp is operating, dispose of lamp with care.
7. Halogen cycle lamps operate at high temperatures. Do not store or place flammable materials near lamp.
8. Do not use this equipment for other than intended use.
9. All servicing should be performed by qualified service personnel.

 **Caution! For models including battery support plate (3) it is critical to ensure that the hooked end of the bracket is properly latched to the battery support plate (see Fig. 1). Failure to do so can cause a serious injury.**

 **Caution! Velcro straps are a temporary means to support the batteries. You must always reinstall the battery retaining bracket(11).**

SAVE THESE INSTRUCTIONS

Installation Instructions

1. Turn off unswitched AC power.
2. Route AC unswitched circuit of rated voltage into electrical box and leave 6" of wire length.
3. Lay unit on a flat surface face up. Remove lenses (8) and heat shields (13) (for units with 20W lamps) (See Fig. 1) and leave lamps detached from the housing.
4. Remove the front cover (1).
5. Remove the battery support bracket (11) (See Fig.2) and battery(ies) and note how they are connected to reproduce this upon re-assembly.
6. Determine the mounting position (wall or ceiling).

Wall Mounting

1. Knock-out the proper hole pattern in the housing (6) to mount to a standard junction box (9) (See Fig. 2) according to the required orientation. To do so, it is recommended to place the unit on a flat solid surface with the back of the housing facing the surface. Prop up the unit on a roll of tape or other solid means to facilitate the removal of the knock-outs. Place the tip of a flat head screwdriver in the groove and knock out each detail with the help of a hammer (See Fig. 2).
2. Remove bubble wrap and install lamp assembly (7) (See Fig. 1).
3. Install means to anchor unit in line with "Wall anchoring points" (see Fig. 2). This is recommended for a more secure installation.
4. Install junction box screws until they protrude 1" minimum from the wall.
5. Feed the AC supply leads and wires from remotes (if applicable).

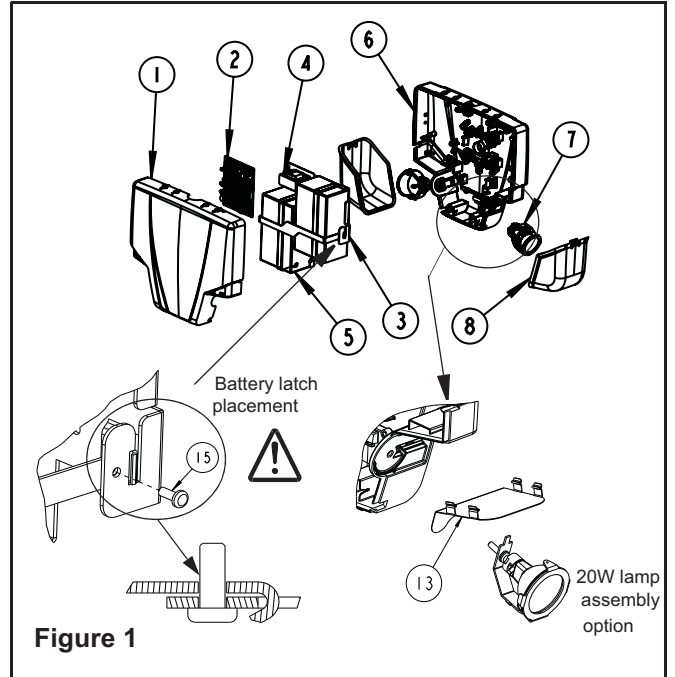

Figure 1

Part List

- | | |
|----------------------------------------------------|------------------------------------------|
| 1. Front cover | 9. Junction box |
| 2. Charger board | 10. Junction box screw 8-32 x 1-1/2" |
| 3. Battery Support plate (only for certain models) | 11. Battery retaining bracket |
| 4. Transformer | 12. Velcro strap |
| 5. Battery (1 or 2 depending on models) | 13. Heat shield (20W units only) |
| 6. Housing | 14. Wall mounting screws (not provided) |
| 7. Lamp assembly | 15. Bracket locking screw |
| 8. Lens | |

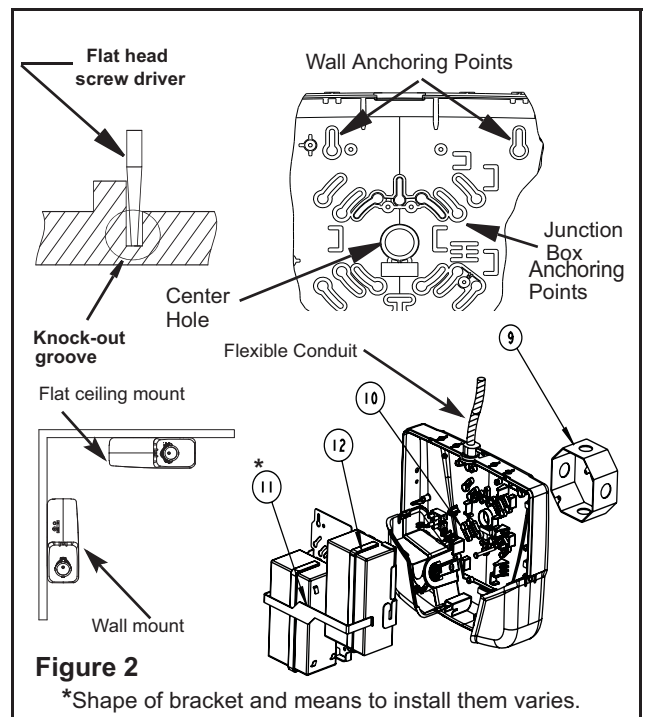

Figure 2

*Shape of bracket and means to install them varies.



Thermoplastic Battery Unit

Emergency Lighting

- Mount housing to the junction box.
- Make the proper connections: our system can accept input voltages of 120 VAC or 277 VAC. Therefore, connect the black (120 VAC) or orange (277 VAC) and white (common) leads to the building utility. Connect the green wire to the ground.

⚠ Unused primary wire must be insulated to prevent shorting.

Route entry wires to avoid contact with the transformer, battery terminals and charger PCBA. Refer to figure 3.

- Secure the housing to the wall at wall anchoring points using wall mount screws (14), then to the junction box using the junction box screws (10).
- Connect the tips of each Velcro strap to form the largest possible loop.
- Reinstall the battery(ies) by connecting the wires first before securing each battery in the housing. Secure the Velcro strap(s) and battery bracket with locking screw (15) when supplied. Connect the battery to the charger board.
- For units with remote capacity, connect the remote heads to L+ and to L-.

Calculation of total allowable remote capacity of unit:

Maximum remote lamp power = unit capacity minus the total power of lamps included with unit.

- Adjust the lamps in an appropriate position.
- Put the unit cover back in place.
- Install the heat shields (units with 20W lamps only) and lenses.
- Energize AC.

Flat Ceiling Mounting (optional)

Follow same steps as outlined for Wall Mounting. No canopy is required. (See Fig.2.)

⚠ Caution! DO NOT install unit to the ceiling unless its model number includes the suffix " -CM "

Pendant Mounting

Refer to Addendum for Pendant Mounting.

Conduit Entry Connection (Flexible conduit only)

Remove knock-out for the conduit entry located on the top of the housing (See Fig. 2).

Secure unit to the wall following "Wall mounting" or "Ceiling mounting" instructions and make appropriate connections. Isolate wires from building to avoid contact with the transformer.

Manual Testing

Press test switch. On release, external green LED will illuminate and automatic charger will restore battery to full charge.

Automatic Testing

The unit will perform an automatic self-test of 1 minute every month, 10 minutes every 6 month and a 30 minutes self-test once a year.

Automatic Diagnostics

The diagnostic function uses an external LED Status indicator. Service is required if the LED blinks indicating that an alarm condition is detected (See Fig. 4). For more information refer to the website address indicated on the unit label located inside the unit. For more information about the AD function, please consult the web site for this user manual:

"AD with Single LED Status User Manual"

For Nexus models, refer to "Nexus addendum" and for any additional information, go to www.Nexus-System.com.

If you wish to make the unit "audible" or "non-audible" simply re-orient the jumper "JP5" as shown in figure 4.

Maintenance

None required. If AC supply to the unit is to be disconnected for 2 months or more, the battery must be disconnected.

Note — Nickel Cadmium battery units are shipped discharged and may require 10 minutes of connection to AC supply before start-up test procedure, and 96 hours to reach full charge or 24 hours to charge to meet a 30 minute discharge.

*Flexible conduit or Pendant mount wire configuration

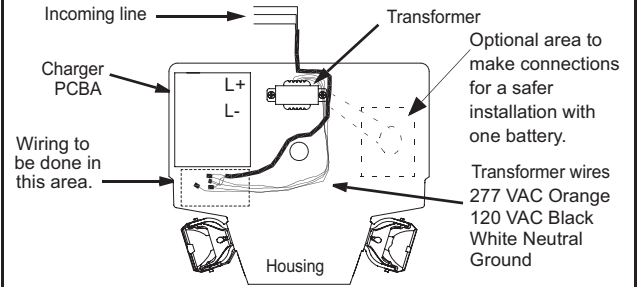

⚠ Caution: Route entry wires to avoid contact with the transformer, battery terminals and charger PCBA.

*Wall or ceiling mount wire configuration

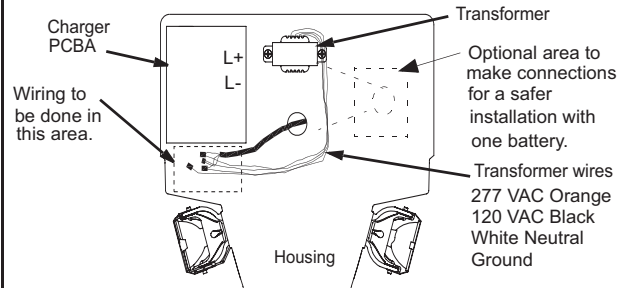

*Wire configuration with battery(ies) installed

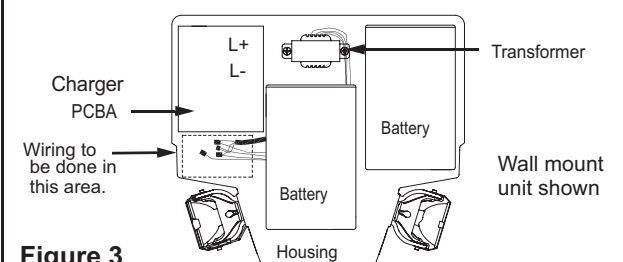

Figure 3

*Unused primary wire must be insulated to prevent shorting.

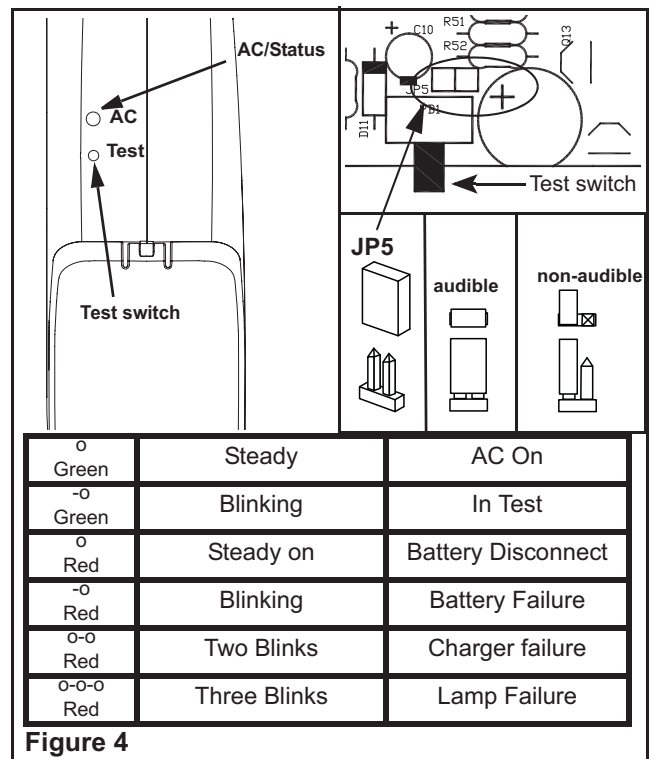

Figure 4