

# EMIU 1000W -4C Option Mini Inverter INTERRUPTIBLE EMERGENCY LIGHTING UNIT INVERTER INSTRUCTION MANUAL

## IMPORTANT SAFEGUARDS

When using electrical equipment, basic safety precautions should always be followed, including the following:

### READ THIS MANUAL AND FOLLOW ALL SAFETY INSTRUCTIONS THOROUGHLY BEFORE OPERATING THE EMIU INVERTER SYSTEM

**i** BEFORE CONTACTING TECHNICAL SUPPORT MAKE SURE TO FOLLOW ALL STEPS IN SEQUENCE AND REFER TO THE TROUBLESHOOTING GUIDE INCLUDED IN THIS MANUAL.

## SAVE THESE INSTRUCTIONS

1. Install in accordance with the National Electrical Code and local regulations.
2. The **EMIU** contains potentially hazardous voltages. Installation, maintenance and service work should be performed by qualified and trained personnel.
3. Units to be installed only as per configuration described in this instruction manual.
4. Electricians and end-users need to ensure product system compatibility before final installation.
5. The AC voltage rating of this equipment is specified on the product label. Do not connect the **EMIU** equipment to any other voltage.
6. All unused wires must be capped to prevent shorting.
7. The **EMIU** should be mounted securely and in locations and at heights where it will not be readily subjected to tampering by unauthorized personnel.
8. The use of accessory equipment and replacement parts not recommended by manufacturer may cause an unsafe condition and will void the warranty.
9. Do not mount near gas or electric heaters.
10. Do not let power supply cords touch hot surfaces.
11. Do not use this equipment for other than its intended use.
12. DO NOT USE OUTDOORS.
13. The **EMIU** uses sealed valve regulated lead acid batteries. Batteries can be punctured if not handled properly, therefore use caution when servicing batteries. In the event battery acid comes in contact with eyes or skin, flush with fresh water and consult a physician immediately.

MODEL NUMBER	AC SPECS		EMERGENCY POWER AVAILABLE FOR LOAD				APPROX. WEIGHT
			90 MIN	2H	3H	4H	
EMIU1000W - 4C option	120/277 VAC, 60Hz	12.8 / 5.3 Amps	1000W	807W	604W	489W	320lbs.

**NOTE: At 120Vac, unit is rated at power factor 0.8. For loads having a power factor below 0.8, unit capacity needs to be derated. At 277Vac, unit is rated at unity power factor. For loads having a power factor below 1, unit capacity needs to be derated.**

## WARRANTY

All ABB inverter products receive 100% quality inspection before shipment to ensure proper and satisfactory operation. When operated under normal conditions, ABB inverter products will provide years of dependable service. This unit is backed by a 3-7 year warranty. The unit is covered by a complete 3-year warranty against defects in material or workmanship, and a 7-year pro-rata battery warranty.



**WARNING:** DE-ENERGIZE THE CIRCUIT BEFORE INSTALLATION OR MAINTENANCE.



**WARNING:** DO NOT ENERGIZE THE CIRCUIT UNTIL ALL STEPS HAVE BEEN SUCCESSFULLY COMPLETED.



**WARNING:** ALWAYS TURN OFF THE INVERTER MODULE AND THE AC SUPPLY TO THE EQUIPMENT AND DISCONNECT THE BATTERY BEFORE SERVICING. ONLY QUALIFIED SERVICE TECHNICIANS SHOULD SERVICE THIS EQUIPMENT. THE USE OF PARTS SUPPLIED BY OTHER THAN THE MANUFACTURER MAY RESULT IN AN UNSAFE CONDITION OR EQUIPMENT FAILURE AND WILL VOID THE WARRANTY.



**WARNING:** DO NOT CONNECT THE BATTERIES UNTIL YOU ARE PREPARED TO START-UP THE UNIT PERMANENTLY. CONNECTING THE BATTERIES WITH THE UNIT OFF FOR A PROLONGED PERIOD MAY DRAIN THE BATTERIES TO THE POINT THAT YOU WILL NOT BE ABLE TO START-UP THE UNIT.



**WARNING:** FAILURE TO CONNECT THE BATTERIES PROPERLY MAY RESULT IN EQUIPMENT FAILURE OR AN UNSAFE CONDITION AND WILL VOID THE WARRANTY. A SMALL SPARK MAY OCCUR WHEN CONNECTING TO THE BATTERY WIRES. THIS IS NORMAL AND IS CAUSED BY LARGE CAPACITORS CONTAINED IN THE MINI INVERTER BEING CHARGED.



**CAUTION:** THE BATTERIES ARE SHIPPED SEPARATELY. PLACE THEM IN A LOCATION AWAY FROM THE WORK AREA TO AVOID DAMAGE UNTIL THEY ARE READY TO BE INSTALLED.



**CAUTION:** THIS UNIT PROVIDES MORE THAN ONE POWER SUPPLY OUTPUT SOURCE. TO REDUCE THE RISK OF ELECTRICAL SHOCK WHEN SERVICING, DISCONNECT BOTH NORMAL AND EMERGENCY SOURCES BY TURNING OFF THE A.C. BRANCH CIRCUIT AND BY DISCONNECTING THE BATTERY.



**CAUTION:** ONLY ONE VOLTAGE IS ALLOWED (120V OR 277V). CONNECTION TO MORE THAN ONE VOLTAGE MAY RESULT IN EQUIPMENT FAILURE AND VOID THE WARRANTY.



**CAUTION:** THE MINI INVERTER HAS A SELF-TEST FEATURE AND CAN ENTER IN SELF-TEST MODE (MONTHLY, BIENNIAL OR ANNUAL) AT ANY TIME. WHEN THIS OCCURS, POWER WILL BE AVAILABLE AT THE OUTPUT OF THE MINI INVERTER, EVEN IF THE LATTER WAS CONFIGURED FOR NORMALLY-OFF OPERATION. ALWAYS TURN OFF THE INVERTER MODULE INSIDE THE MINI INVERTER BEFORE WORKING WITH THE WIRING SYSTEM OF THE EMERGENCY LIGHTING SYSTEM.



**IMPORTANT:** FOLLOW THE APPROPRIATE WIRING DIAGRAMS. DO NOT CONNECT THE "INPUT POWER" NEUTRAL TO THE "LOAD" NEUTRAL. FAILURE TO COMPLY WITH THIS DIRECTIVE MAY RESULT IN EQUIPMENT FAILURE AND VOID THE WARRANTY.



**IMPORTANT:** FOR NORMALLY OFF AND SWITCHED LOADS: REMOVE THE JUMPER WIRE BEFORE WIRING THE UNIT. REFER TO THE WIRING DIAGRAMS.

## INSTALLATION

### STEP 1: MOUNTING THE MINI INVERTER TO WALL (SEE FIGURE 1)

- a. Remove the front cover of the Mini Inverter cabinets by removing the two screws located on the front of the cover.
- b. Extend the unswitched, properly-rated AC voltage supply and remote fixture wires to the installation area.
- c. Orient cabinets to ensure clearance is 3.5 inches on either side of the Mini Inverter and 42 inches on the front. No clearance is required on the bottom of the unit. For units equipped with optional wireless Nexus, a clearance of 6 inches is required on top to allow for the protruding antenna. For units without wireless Nexus, no clearance is required on the top.
- d. Mount the battery cabinet securely to the wall using the keyhole slots at the rear of the cabinet. Leave a minimum of 36 inches above the battery cabinet for the electronic cabinet.
- e. Place the electronic cabinet on top of the battery cabinet and align the four bolt/nut assemblies to the holes located on top of the battery cabinet.
- f. Install and tighten the lock washers and nuts onto the bolts inside the battery cabinet.
- g. Mount the electronic cabinet securely to the wall using the keyhole slots at the rear of the cabinet.



**WARNING:**

**MINI INVERTER MUST BE MOUNTED SECURELY USING A 1/4" (MIN) SCREW AND FLAT WASHER FOR EVERY KEYHOLE. THE MOUNTING SURFACE MUST ALSO BE SUFFICIENTLY REINFORCED TO ACCOMMODATE THE WEIGHT LISTED (SEE PAGE 1). FAILURE TO SECURE THE UNIT SUFFICIENTLY CAN DAMAGE THE EQUIPMENT AND/OR CAUSE SERIOUS INJURY.**

- h. Route the blue and red wires through the two holes located at the bottom of the electronic cabinet to the battery cabinet.
- i. Connect the conduit containing the AC supply and remote fixture leads to the electronic cabinet. Use the provided knock-outs on the side of the electronic cabinet to connect the incoming wires.
- j. Install the batteries, **DO NOT** connect the battery leads at this point until other wiring is completed.
- k. Route the ground (green wire) from the electronic cabinet to the battery cabinet. Bolt the ground wire to the battery cabinet using the nut and bolt provided.



**CAUTION: CABINETS ARE HEAVY AND AWKWARD TO LIFT. MAKE PROPER PROVISIONS TO ENSURE SAFETY OF INSTALLERS.**

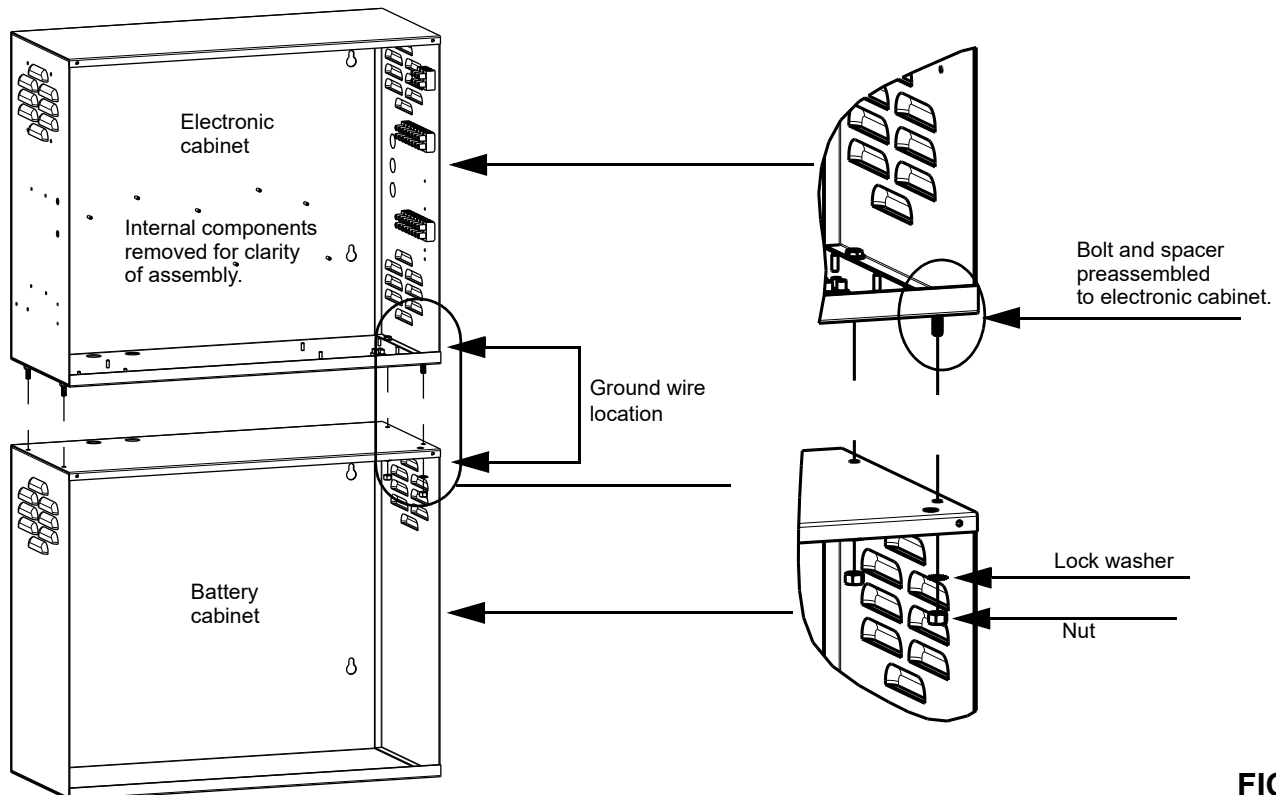

**FIGURE 1**

## ELECTRICAL SINGLE LINE DIAGRAM FOR EMIU 1000W WITH 4 CIRCUITS (-4C OPTION)

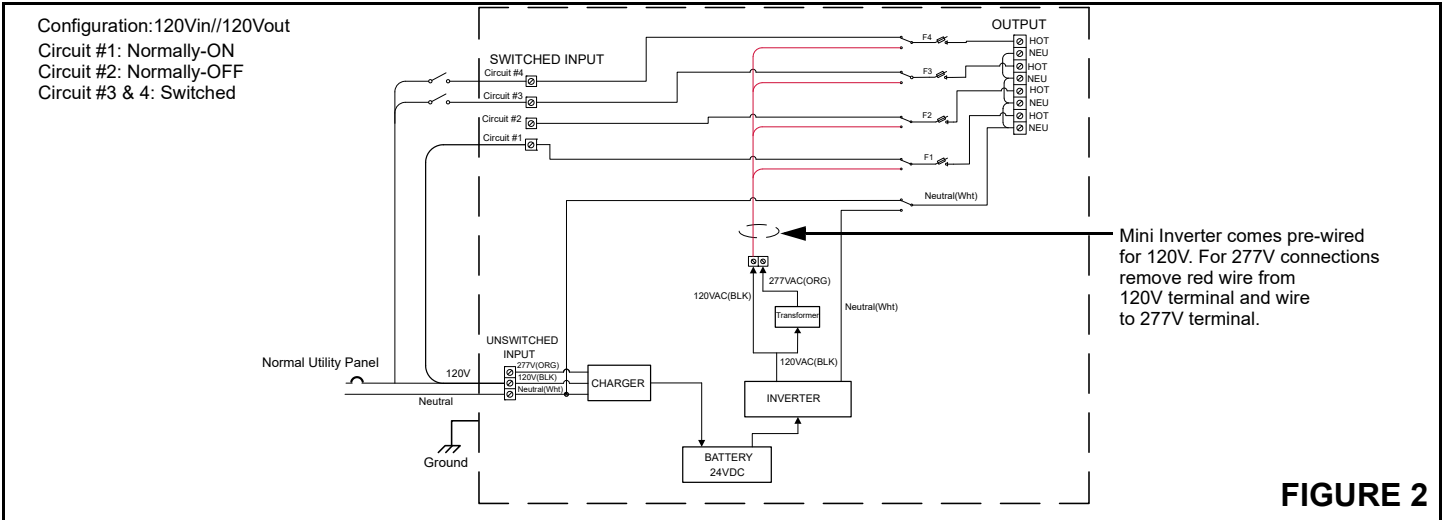
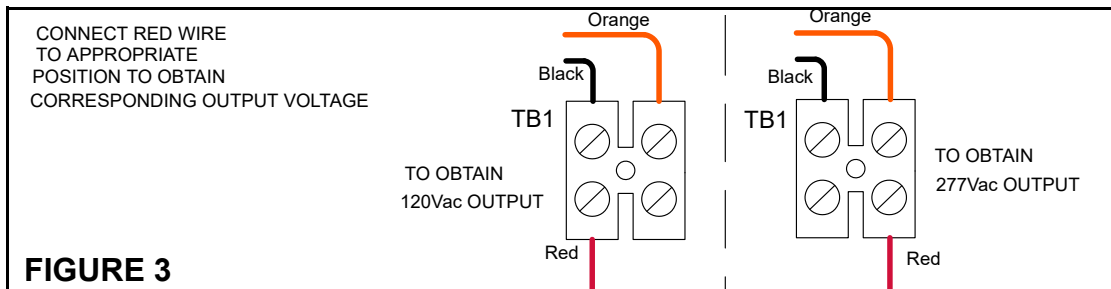

**FIGURE 2**

- Mini Inverter with option -4C can control four individual circuits (see figure 2).
- Unit can be configured for either 120V in // 120V out or 277V in // 277V out.
- Power applied to the UNSWITCHED INPUT charges the batteries.
- The four SWITCHED INPUTS can each be configured to operate Normally-On, Normally-Off or Switched loads.
- Power supplied to the switched inputs must be fed from the same branch circuit as the unswitched input (see figure 2).**
- Unit is shipped from factory pre-set for 120V in // 120V out and configured for Normally-On load operation (see figure 2). This configuration can be changed to fulfill customer's application.
- In Normal AC mode, the load connected at the output is powered by the power applied to the SWITCHED INPUT.
- In Emergency mode, the load is powered by the battery through the inverter. The inverter converts the battery DC power to AC power.

### STEP 2: CONFIGURATION OF OUTPUT VOLTAGE (SEE FIGURE 2 AND 3)

- Output voltage of the Mini Inverter with option 4C can be configured for either 120VAC or 277VAC.
- Identify the terminal block TB1 located on the bottom of the electronic cabinet.



**FIGURE 3**

- Position of the red wire determines the voltage available at the output of the Mini Inverter.
- When the red wire is connected at the left terminal of TB1, the output voltage available will be 120VAC.
- When the red wire is connected on the right terminal of TB1, the output voltage available will be 277VAC.
- Identify the voltage rating of all the loads to be powered by the Mini Inverter.
- If the voltage rating of the loads is 120VAC, connect the red wire to the left terminal of TB1.
- If the voltage rating of the loads is 277VAC, connect the red wire to the right terminal of TB1.

### STEP 3: WIRING TO UNSWITCHED INPUT

**WARNING:** PRIOR TO MAKING ANY WIRING CONNECTIONS TO THE MINI INVERTER, MAKE SURE THE BRANCH CIRCUIT BREAKER FEEDING THE UNIT IS TURNED OFF AT THE SERVICE PANEL.

- Connect the Ground wire to the Ground Bus Bar.
- Identify the terminal block for UNSWITCHED INPUT (figures 6, 7, 8 or 9).
- Connect the NEUTRAL wire to the NEUTRAL position of the UNSWITCHED INPUT terminal block.
- For 120V supply, connect the AC Line wire to the 120V position of the UNSWITCHED INPUT terminal block. For 277V supply, connect the AC Line wire to the 277V position of the UNSWITCHED INPUT terminal block.

## STEP 4: WIRING TO SWITCHED INPUT

**CAUTION:** POWER SUPPLIED TO THE SWITCHED INPUTS MUST BE FED FROM THE SAME BRANCH CIRCUIT AS THE UNSWITCHED INPUT.

The Mini Inverter model with 4C option can be configured for various modes of operation as described below.

- a. **Normally-On Operation** (Refer to Figure 6 for wiring details) - Fixtures remain illuminated in normal AC and emergency modes.
- b. **Normally-Off Operation** (Refer to Figure 7 for wiring details) - Fixtures illuminated only upon loss of utility AC power.
- c. **Switched Load Operation** (Refer to Figure 8 for wiring details) - Fixtures can be externally controlled and will illuminate upon loss of utility AC power regardless of the state of the external control device (switch, motion sensor, dimmer, etc.).
- d. **Combination of Normally-On, Normally-Off and Switched Load Operation** (Refer to Figure 9 for wiring details) - Each circuit in the Mini Inverter with the 4C option can be configured in one of the previously described modes of operation.

Refer to the applicable wiring diagram in figures 6, 7, 8 and 9 to connect the utility AC power and external control devices (where applicable). Perform all wiring procedures in accordance with applicable codes. The unit is shipped configured to operate in Normally-On mode by using an assembled jumper. This jumper can be removed to configure the SWITCHED INPUTS as desired.

Do not connect the load to the Mini Inverter at this point of time.

**CAUTION:** ALL FOUR SWITCHED INPUTS HAVE BEEN JUMPERED AND IS PRESET FOR 120VAC TO OPERATE NORMALLY ON LOADS. IF THE UNIT IS TO BE WIRED FOR 277VAC, REMOVE THE JUMPER WIRE FROM THE 120VAC INPUT POWER TERMINAL AND REINSTALL THE JUMPER WIRE INTO THE 277VAC INPUT POWER TERMINAL.

**CAUTION:** IF CONNECTED TO 277V SWITCHED INPUT, USE A 277V RATED SWITCH. FAILURE TO USE THE PROPER VOLTAGE SWITCH MAY RESULT IN SWITCH FAILURE, A SHOCK HAZARD, AN UNSAFE CONDITION AND/OR EQUIPMENT FAILURE.

## STEP 5: CONNECT BATTERIES (SEE FIGURE 4)

- a. Position the batteries in cabinet as shown. Make sure to respect the battery polarities.
- b. The battery assembly consists of two battery strings, 24Vdc nominal each. Each battery string consists of two 12V batteries connected in series. "Battery 1" and "Battery 2" form the first string. "Battery 3" and "Battery 4" form the second string. The two 24V battery strings are connected in parallel.
- c. Route the RED(positive) and BLUE(negative) battery cables plus the thin yellow cable (AWG#22) from the electronic cabinet to the battery cabinet.
- d. Connect the battery interconnect cables ALONG WITH THE THIN YELLOW CABLE (AWG# 22).
- e. Measure the DC voltage between the yellow cable and the main negative terminal of the battery bank. Confirm voltage is between 12V and 13V.
- f. Connect the BLUE(negative) cable routed from the electronic cabinet to the main negative terminal of the battery bank.
- g. Measure the DC voltage between the main positive terminal and the main negative terminal of the battery bank. Confirm voltage is between 24V and 26V. If measured voltage is different, check battery wiring.
- h. Connect the RED(positive) cable routed from the electronic cabinet to the main positive terminal of the battery bank.
- i. Tighten all bolts to a torque of **78 lbf-in ± 4 lbf-in**.

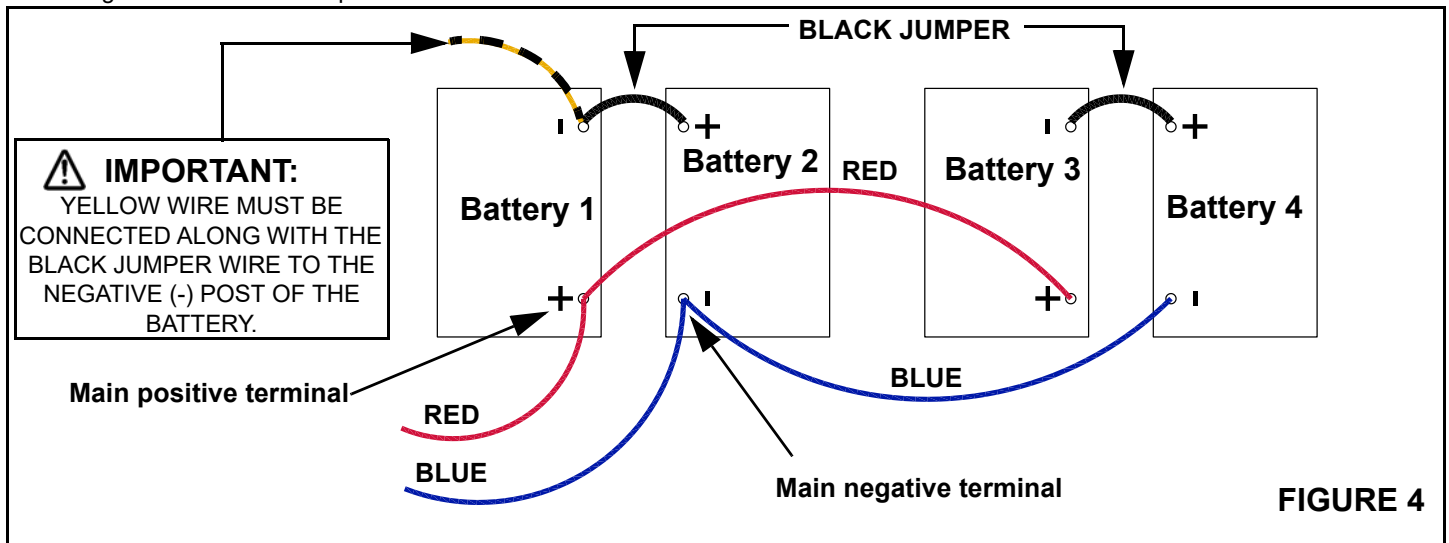

**STEP 6: START-UP WITH NO LOAD CONNECTED.**

- a. Confirm load is not connected.
- b. Follow start-up procedure in Step 7.

**STEP 7: START-UP PROCEDURE**

- a. Turn on switch located on right hand side of inverter module in the electronic cabinet. Emergency lights and indicator will not illuminate.
- b. Energize AC mains supply. Status Indicator on the left side of electronic cabinet will illuminate. For more information about the Status Indicator, see information section FEATURES AND OPTIONS.
- c. If status LED Indicator is not green, reset the system. (Refer to "SYSTEM RESET" on page 7).
- d. Manually test unit by pressing test switch for 1 second. (Refer to "MANUAL TEST" on the page 7).
- e. Measure and record voltage at the output of circuits 1, 2,3 and 4.
- f. Confirm measured output voltages match voltage rating of the loads.
- g. Following the 1 minute test, simulate a power outage by turning off the AC mains circuit breaker feeding the Mini Inverter.
- h. Measure and record voltages at the output of circuits 1, 2,3 and 4.
- i. Confirm measured output voltage match voltage rating of the loads. If voltages do not match, check the wiring or call Technical Support.

**STEP 8: SHUT DOWN PROCEDURE.**

- a. Turn off switch located on right-hand side of inverter module in the electronic cabinet.
- b. Turn off AC mains circuit breaker in the service panel feeding the Mini Inverter.

**STEP 9: CONNECT THE LOAD.**

- a. Before proceeding, confirm all circuits are de-energized.
- b. Upon confirmation that measured output voltage of Mini Inverter matches voltage rating of loads, wire load.
- c. Identify output terminal block (refer to figures 6, 7, 8 and 9).
- d. The neutrals of circuit# 1, circuit# 2, circuit# 3 and circuit# 4 are shorted at the output terminal block as shown in figure 2.
- e. Connect Ground wires from loads to Ground Bus Bar.
- f. Connect neutral wires from loads to neutral terminals of output terminal block.
- g. The neutrals of emergency fixtures must be wired to output terminal block.
- h. Do not connect the neutral wire of emergency fixtures to neutral wire of normal non-emergency lighting.
- i. Connect hot wires from emergency lighting loads to the "HOT" terminals of OUTPUT terminal block.

**STEP 10: START-UP WITH LOAD CONNECTED.**

- a. With loads connected, follow the start-up procedure in Step 7.
- b. Normally-ON fixtures must be ON, Normally-OFF must be OFF. Switched Emergency Fixtures must only be ON when switch is in ON position.
- c. Re-install the cover of the Mini Inverter using original hardware.

## NEXUS<sup>®</sup> (OPTION)

### Wired:

- Route NEXUS<sup>®</sup> data cables into unit and strip one inch (25mm) of the cable insulation. Two cables are identical and contain 2 wires of different colors: color A and color B.
- Connect both color "A" wires to the same pole on the terminal block. Connect both color "B" wires to the same pole on the terminal block. The result must be 2 wires of the same color connected to each pole on the terminal block. See Figure 5.
- Live voltage cabling and unsheathed low voltage data cabling must be a minimum of one inch (25mm) apart.

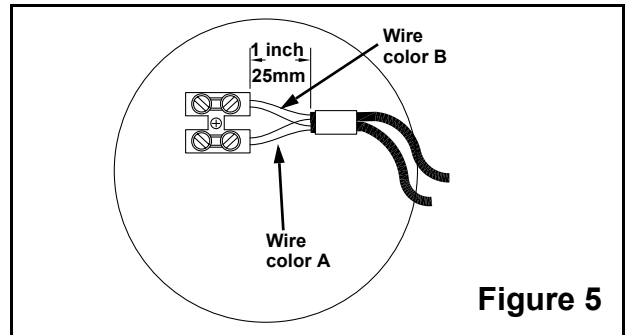

### Wireless:

**NO WIRING IS REQUIRED FOR THE NEXUS<sup>®</sup> WIRELESS VERSION.**

See addendums: 750.1532 and 750.1641 for more information and antenna installation.

## MANUAL TEST

Press test switch for 1 second to initiate a 1 minute manual test. Status Indicator will start flashing green. All normally-ON lamps (switched or unswitched) will turn ON. All normally-off lamps shall also be ON. After 1 minute test lamps will revert to their normal operating mode and unit will revert to recharge mode. Status indicator will be steady ON green if no fault has been detected. If a fault is detected, refer to the FEATURES AND OPTIONS instructions on pages 12 to 14 for diagnostics and auto test features.

Allow the batteries to charge for a minimum of 48 hours after installation or power failure before conducting a 90-minute discharge test. The Life Safety Code and the Authorities having Jurisdiction require an annual 90-minute discharge test.

## SYSTEM RESET

### Resetting the system:

Depending on the sequence of installation, some units may require a system reset. To reset, press and hold test switch on left side of unit for 6 seconds.

## MAINTENANCE

### BATTERY:

The batteries supplied in this equipment are high quality maintenance-free Valve Regulated Lead Acid design.

When installed in an ambient temperature of 25° C (77° F), their life expectancy is 8 to 10 years.

When batteries will no longer operate the load for 90 minutes, they must be replaced. Replace only with manufacturer supplied parts.

Properly dispose of or recycle the Lead-Acid battery.

## NORMALLY-ON OPERATION

All four(4) circuits configured to operate in Normally-On mode.

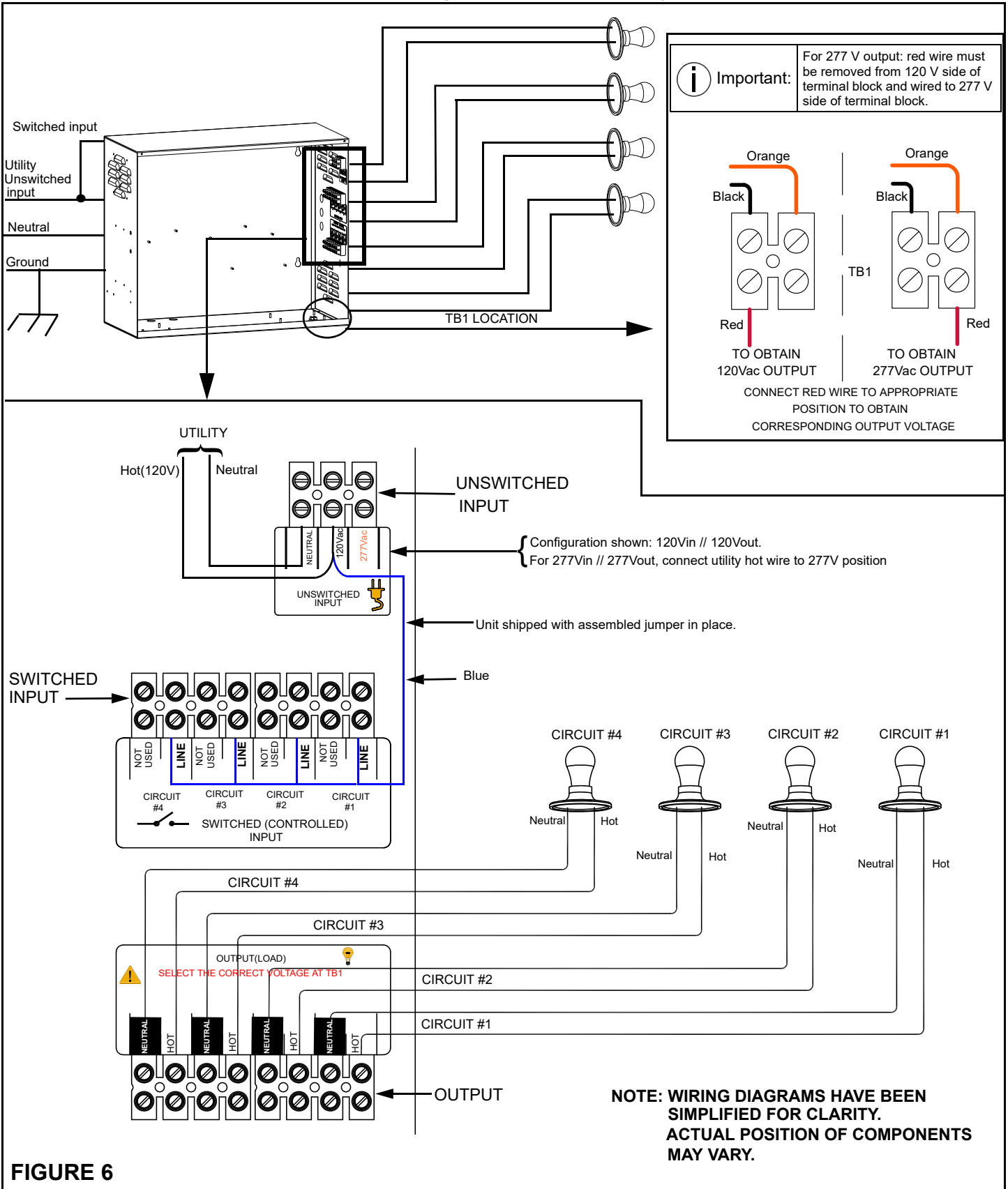

FIGURE 6



## NORMALLY-OFF OPERATION

All four(4) circuits configured to operate in Normally-Off mode.

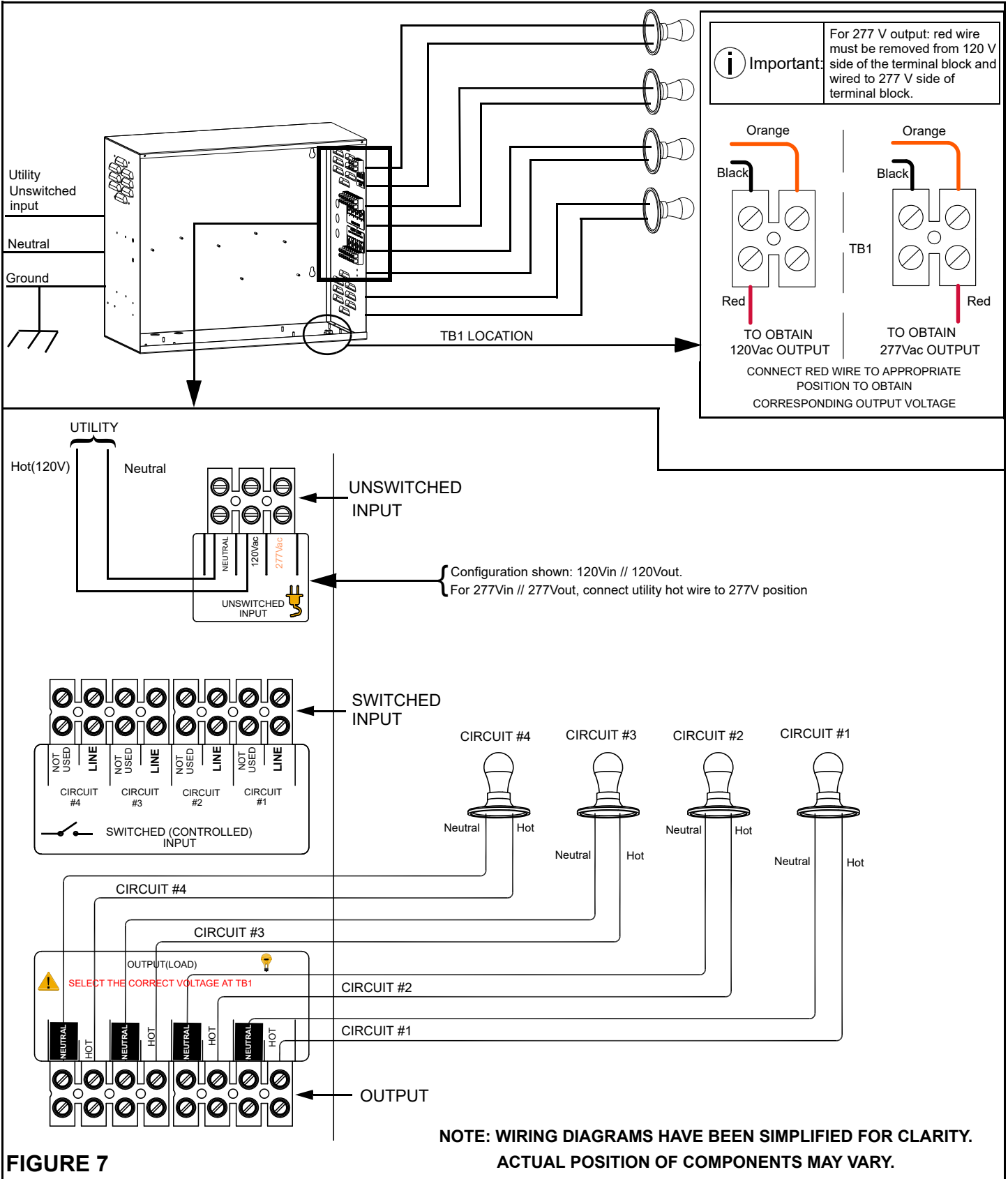

FIGURE 7

## SWITCHED LOAD OPERATION

All four(4) circuits controlled by switches.

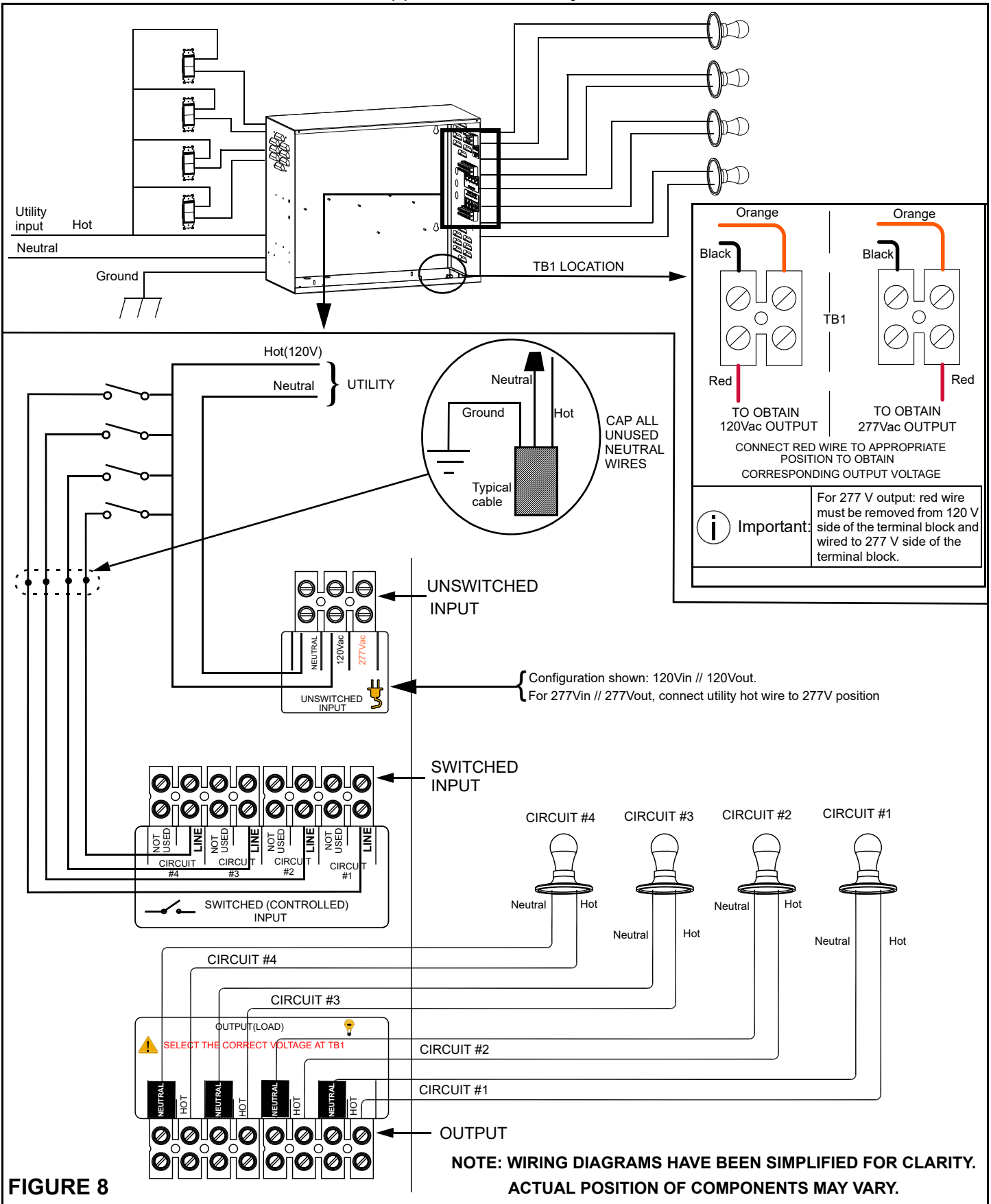

FIGURE 8

## COMBINATION OF NORMALLY-ON, NORMALLY-OFF AND SWITCHED LOAD OPERATION

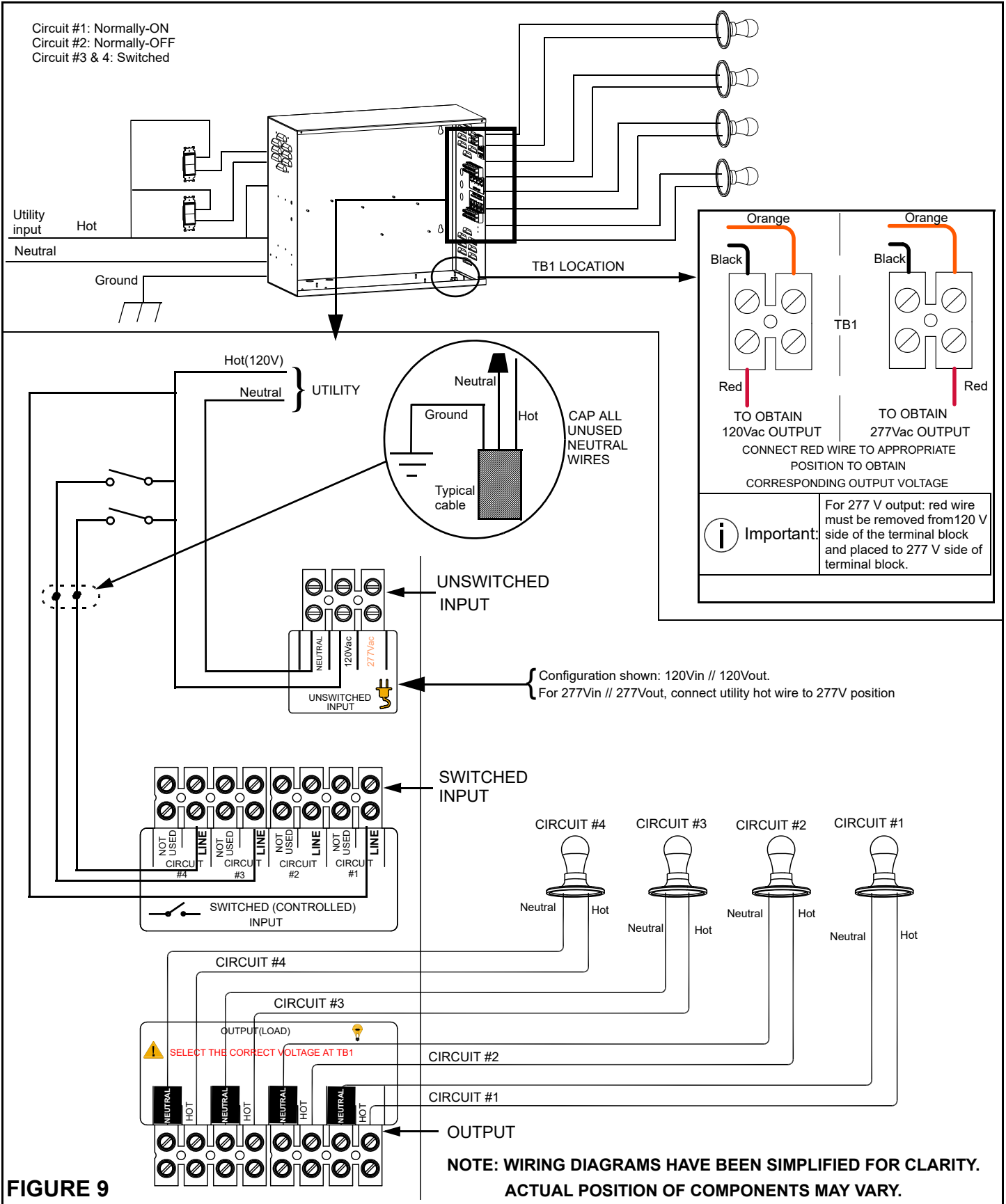

FIGURE 9

# FEATURES AND OPTIONS

## SYSTEM OPERATION

- The diagnostic/charger is a self-contained, fully automatic microcontroller-based system.
- When installation is complete, only the battery connection is needed. AC power need not be energized.  
Unit goes directly into lockout mode and waits for AC power to be restored.

### 1. ALARM SILENCE / MANUAL TEST / SYSTEM INITIALIZATION

- Alarms are silenced by pushing the “TEST” switch less than one half second. Alarm can only be silenced after correcting the fault or by re-initializing the system.
- Press the “TEST” switch for 1 second to initiate a 1 minute manual test
- System initialization is done by holding “TEST” switch for at least 6 seconds.

### 2. DIAGNOSTIC AND NEXUS® (OPTION)

If audible alarm is activated, any fault condition will produce an audible warning of an intermittent beep: one second on, one second off.

See figure 10 for fault indicators.

#### a. BATTERY DISCONNECT / INVERTER FAILURE

Status indicator displays steady red LED if battery circuit is open or shorted, or if there is an Inverter failure.

#### b. BATTERY FAILURE

1 red blink and a pause of 5 seconds: incorrect battery (e.g. 12V battery on a 6V system), or battery has failed a timed or forced test (reached LVD level before the end of the test).

#### c. CHARGER FAILURE

2 red blinks and a pause of 4 seconds: charging current is not within limits corresponding to charger command state.

#### d. LIGHTING LOAD CAPTURE SEQUENCE

Only initiated by a reset of system. Press “TEST” switch for at least 6 seconds. Reset initializes the main counter. This re-initialization takes place to compensate for system variations when the unit ages. Re-initialization is not allowed if there is a lighting load failure alarm. This is not applicable for units with “No-Auto-Test plus No-Load-Detect” option.

#### e. SERVER FAILURE

The Nexus server (controller or PC) is no longer communicating with the RF unit’s modem. Confirm Nexus server is operating and check whether other surrounding emergency lighting units are not powered. If surrounding emergency lighting units are powered “off”, the surrounding emergency lighting units will prevent communication with the modem. Otherwise, reset the modem.

#### f. BLINK MODE

A “Blink mode” signal was sent from the Nexus server (controller or PC) to the emergency lighting unit. To stop the “Blink mode”, access the Nexus server and execute a stop blink mode operation.

#### g. NOT COMMISSIONED

The unit is not registered in the Nexus server. Commission the unit. Auto-test will be disabled and the LED will show a steady green for 10 seconds and steady orange for 1 second.

To cancel a fault alarm display, reset unit after issue correction.

\*Refer to Nexus® installation addendum for more details.

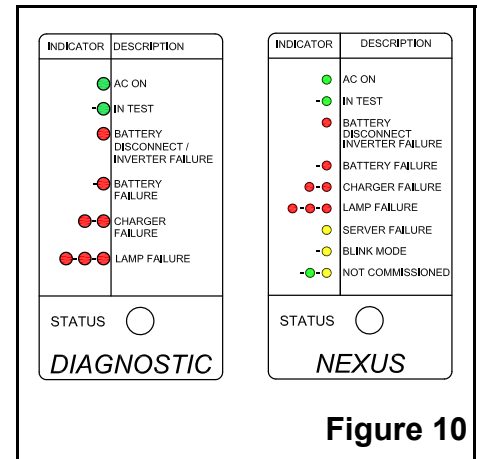

**Figure 10**

**⚠ IMPORTANT:** Reset the system for each addition or change of lighting load. Press test switch for 6 seconds to reset the system.

### 3. AUTOMATIC UNIT TEST (30-DAY TEST)

Every 30 days, while in charging mode, the sequence generator will generate a command to energize the transfer on the emergency lighting circuit for a variable test period depending on the yearly sequence.

	US (MIN)
Monthly test	1
6 month test	30
12 month test	90

**i NOTE:** AUTO-TESTING IS NOT PROVIDED IN SOME UNITS. REFER TO FEATURE 8.

- If the battery fails to complete the discharge test, the charger will display a battery failure and the test will abort.
- The 30-day automatic test sequence is reset every time the lighting load is turned on, including after a manual test.

### 4. LIGHTING LOAD TESTING

The test is fully automatic. To ensure accurate data from a connected and functional lighting load:

- The battery must be at or near full power. The program will delay data capture for a minimum of 48 hours following any discharge or reset.
- The charger must be in hysteresis mode (charger cycling on/off).

**IMPORTANT:** A minimum lamp load equivalent to 10% of the rated capacity of the unit must be installed.  
**Example:** 100W for a 1000W inverter unit.

### 5. AUDIBLE ALARM (BUZZER)

Can be activated or de-activated in the field. Refer to Figure 11.

To select the audible alarm option:

- Remove all power sources to the board (AC and battery).
- Use long-nose pliers to remove the shunt (little black box) from the pins.
- Replace the shunt back according to the option selection.
- Reconnect AC power and the battery.

### 6. SERVICE ALARM CONTACT (OPTION)

If installed, insert each wire of the Building Alarm Panel into separate terminals of the terminal block marked "SERVICE ALARM".

Alarm Panel will provide a 24V signal. The charger board will indicate a fault by closing a contact. Polarity is not specified.

### 7. LIGHTING CONTROL OVERRIDE

This feature is used with lighting loads equipped with low voltage dimming control. The dimming function will be disabled during a power failure in order for the load to provide a 100% light level.

The Mini Inverter comes with four single-pole dry-contact relays that are closed in stand-by operation. In emergency mode (power failure) the contact of each relay opens and the dimming signal from the lighting load is disconnected, allowing the load to operate at 100% light level.

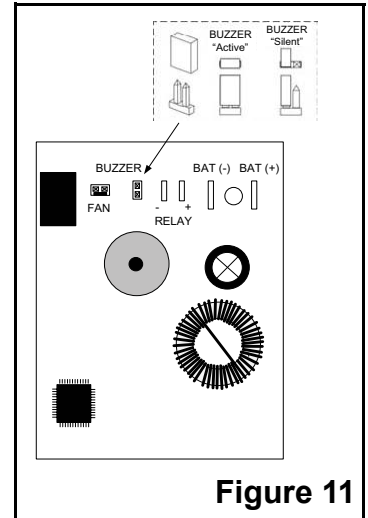

**Figure 11**

**IMPORTANT:** Only one control signal can be handled by one LCO module. Multi control signals require one LCO per control signal. The 1000W Mini Inverter with -4C option comes with four LCO modules.

### INSTALLATION:

1. Locate the Lighting Control signal cable pair.
2. Cut, strip and extend one wire only, of the Lighting Control signal cable.
3. Connect to the terminal block marked "LIGHTING CONTROL OVERRIDE" as shown in the Figures 12 & 13.

Note: Only one output circuit and one LCO are shown in figure 12. The same principle applies to all four output circuits and four LCOs.

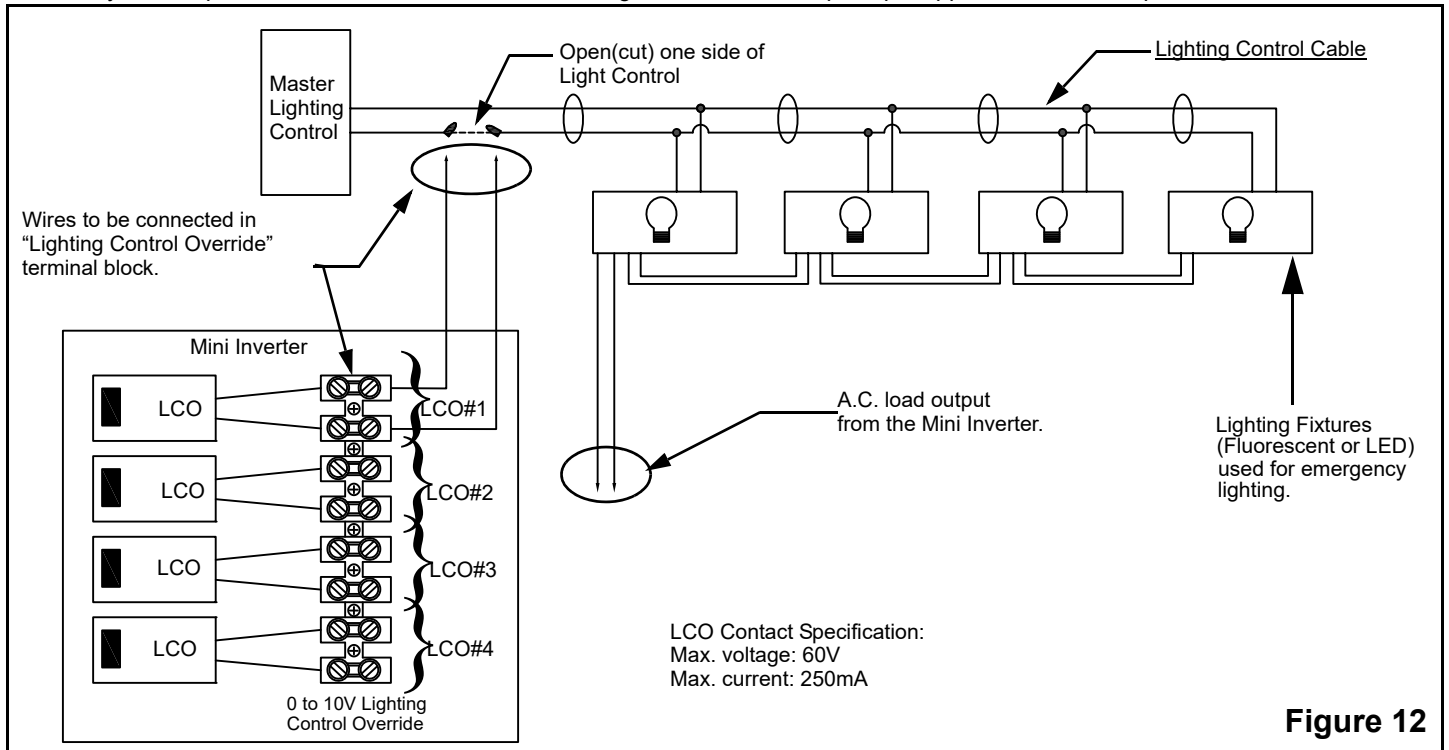

**Figure 12**

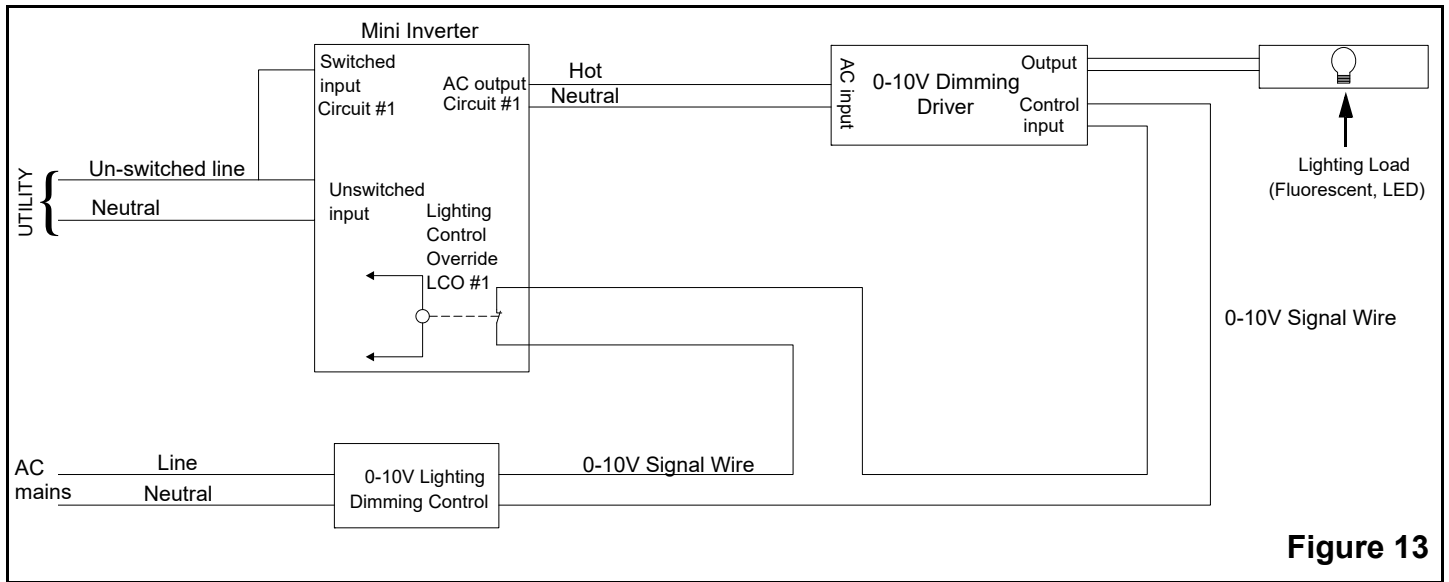

**Figure 13**

### 8. UNITS WITH NO AUTO-TEST (OPTION)

This equipment is not self-testing in conformance with the Life Safety Code, ANSI/NFPA 101.

## TROUBLESHOOTING GUIDE (PAGE 1 OF 2)

STATUS INDICATOR (LED)	TROUBLESHOOTING GUIDE		
	SYMPTOMS	PROBLEM	CORRECTIVE ACTION
 LED GREEN ON Steady, not flashing	Lamp load is on	None, if unit is in normally on mode.	Unit is operating correctly.
	Lamp load is off	None, if unit is in normally off mode.	Unit is operating correctly.
	Lamp load is OFF, but the unit is in normally on mode	Fuses burned out.	Verify there is no short circuit in the load. Replace fuses.
	-Lamp load is OFF (if installation is normally OFF) -Lamp load is ON (if installation is normally ON)	Power at primary AC input + battery discharged (at LVD) + no reaction with test button.	- Remove primary AC input + disconnect battery + wait minimum 10 seconds - connect battery + connect primary AC input => unit will restart - if unit did not restart, call technical support at 1-(888) 552-6467.
 LED flashing GREEN/ORANGE	Lamp load is ON	None if unit is in normally on mode +Nexus option.	Unit is operating correctly. Unit is not commissioned to the Nexus system.
	Lamp load is OFF	None if unit is in normally off mode +Nexus option.	Unit is operating correctly. Unit is not commissioned to the Nexus system.
 LED flashing GREEN/OFF	Lamp load is ON	None the unit is in test mode or is sampling load.	Unit is operating correctly.
	Lamp load is OFF	The output fuse is burnt.	Verify there is no short circuit in the load. Replace fuses.
 LED steady OFF, not flashing	Lamp load is ON	No power at primary AC input + in emergency mode	Check position of breaker feeding the Mini Inverter in the breaker panel. If breaker has tripped, check for overload or short circuit. See "AC SPECS" on page 1.
	Lamp load is OFF	No power at primary AC input + emergency mode stop (battery discharged)	
	-Lamp load is OFF (if installation is normally OFF) -Lamp load is ON (if installation is normally ON)	Power at primary AC input + battery discharged (at LVD) + no reaction with test button	- Remove primary AC input + disconnect battery + wait minimum 10 seconds - connect battery + connect primary AC input => the unit will restart - if unit did not restart, call for technical support at 1-(888)-552-6467.
 LED RED steady ON +  GREEN LED on PCBA charger board steady ON	Inverter Error	In emergency or in test, no output (Inverter switch OFF)	Turn inverter ON/OFF switch to ON position. (Switch is located on right end of inverter module.)
		In emergency or in test, no output (Inverter Failure)	Check inverter control RJ12/RJ50 cable to make sure cable it is properly connected.
		In emergency or in test, output OK (Inverter Sensing defect)	Check if yellow wire is connected. If not, connect. Refer to figure 4.
		In emergency or in test, no output (Inverter Failure)	Reset system(see page 7). If result is the same, replace inverter module.
		Over temperature in emergency or in test	- Verify LED Over Temp/Fault is ON on the inverter. - Verify fan is blocked or not working. - Call technical support at 1-(888)-552-6467.
		Over load in emergency or in test	- Verify LED Overload/Fault is ON on the inverter. - make sure the total load connected does not exceed the units rated capacity. See note on page 1 above warranty information.
 LED RED steady ON	Battery Disconnect Error	No battery installed in unit	Install battery following installation guide.
		The 12V battery sensing not connected	Check if yellow wire is connected. If not, connect. Refer to figure 4.

## TROUBLESHOOTING GUIDE (PAGE 2 OF 2)

<p>LED Flashing RED 1 time every 6 seconds</p>	Battery Failure	Battery fails to complete manual or monthly test.	Replace batteries.
		Battery fails to complete annual test.	Replace batteries.
		Battery fail in charge.	Replace batteries.
<p>LED Flashing RED 2 times every 6 seconds</p>	Charger Failure	Charger not working.	Reset unit (see page 7). If same error display, replace charger board.
<p>LED Flashing RED 3 times every 6 seconds</p>	Lamp Failure	Loss of 10% or more of initial lamp load.	Replace the bad lamp and reset the unit.
	-Lamp Failure -No output voltage	Fuses are burned out.	Verify there is no short circuit in load. Replace fuses.
		Loose connection to terminal block	Verify that all wires are securely connected to terminal block.
<p>LED AMBER (ORANGE) steady On</p>	Network server down	Nexus modem is not sending a signal to Nexus server.	See Nexus manual system.
<p>LED flashing between AMBER/OFF</p>	Wink mode	Unit is in yellow blink mode.	Stop wink mode by sending a message from Nexus server or reset the unit (see page 12).

**CONTACT CUSTOMER SERVICE FOR REPLACEMENT PARTS.  
SERVICING MUST BE PERFORMED BY QUALIFIED PERSONNEL.**

Consult Customer Service for current warranty information.

All information and specifications contained in these instructions are subject to change due to engineer design, errors and omissions.

© 2019 ABB. All rights reserved.



## Mini-Inverter with option "-24" ADDENDUM

Refer to the Mini Inverter Instruction Manual for **IMPORTANT SAFEGUARDS** and general information.

- The Mini-Inverter with option "-24" comes with a 24VDC output.
- The 24VDC output is dedicated to power 0-10V dimming load control module, model number RTS-0-10V-24VDC.
- The RTS-0-10V-24 uses current sinking control scheme.
- During normal ac mode, when utility power is present, the voltage at the output of the designated terminal block is 24VDC.
- During power outage, there will be no voltage present at the 24VDC output.
- **During emergency mode, the total load connected to the Mini-Inverter should not exceed the rated capacity in Watts and VA of the Mini-Inverter.**

### Rating of 24VDC output

- Maximum output power = 26 W
- Output voltage = 24VDC
- Output current range = 0 to 1.08 A
- Quantity of RTS-0-10V-24 modules that can be driven by 24VDC output is 40.

### STEP 1: Connection of Input cable of 24VDC Power Supply:

- Identify the input cable of the 24 VDC Power Supply marked "Connect wire to unswitched position(120V or 277V)" (see Figure 21).
- Connect this cable to the UNSWITCHED INPUT terminal block at either 120Vac or 277Vac position (choose the ac mains voltage being used to power the Mini-Inverter).

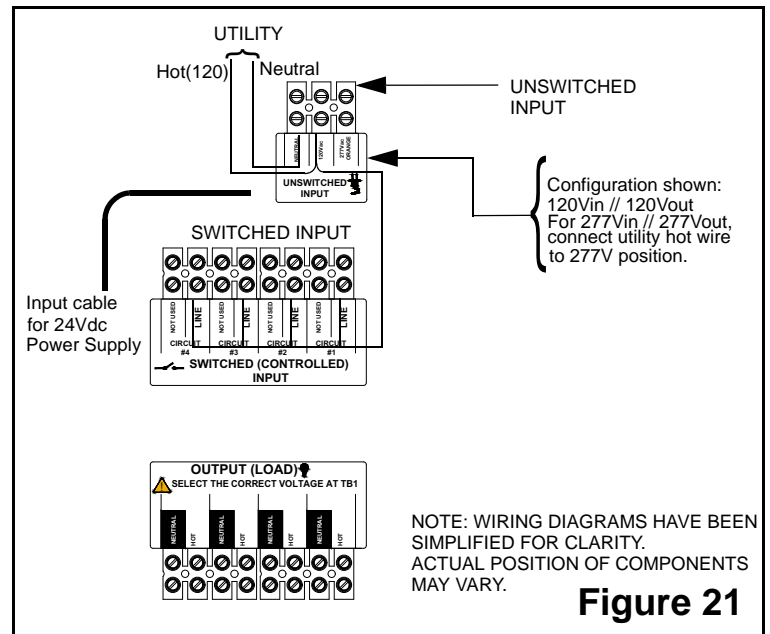

**Figure 21**

### STEP 2: Wiring of Mini-Inverter with RTS-0-10V-24VDC:

- Identify the "+" and "-" terminal blocks dedicated for the 24VDC output (see Figure 22).

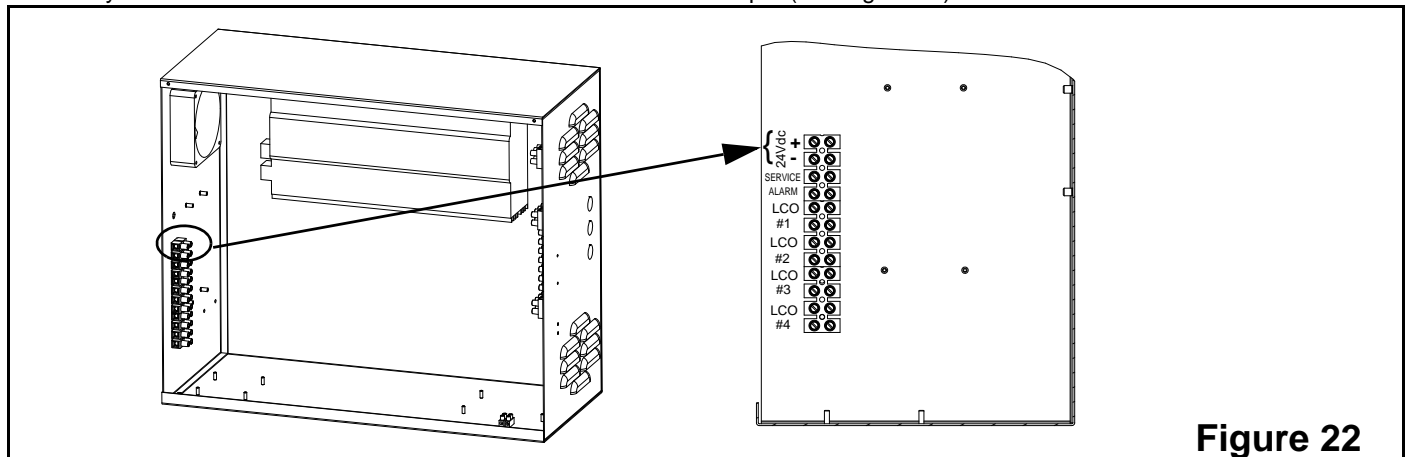

**Figure 22**

- b. Identify the red and the black wires for 24V on the RTS-0-10V-24.
- c. Refer to figure 23 for a simplified wiring diagram (FOR REFERENCE ONLY). Refer to the dimming module (RTS-0-10V) manufacturer's wiring diagram for more information.



**WARNING:**

**LIGHTING OUTPUT ON ANY GIVEN LIGHTING FIXTURE, WHEN WIRING LIGHTING FIXTURES TO AN RTS-0-10V-24 AT A PRE-SELECTED DESIRED DIMMING LEVEL (AS LISTED BELOW), MAY NOT RESPECT THE EXACT LEVEL OF DIMMING STATED IN CONFIGURATION. YOU MUST ALWAYS VALIDATE THAT DIMMED LIGHTING FIXTURES YIELD A MINIMUM LIGHT OUTPUT FOR PATH OF EGRESS PER LIFE SAFETY CODE NFPA101.**

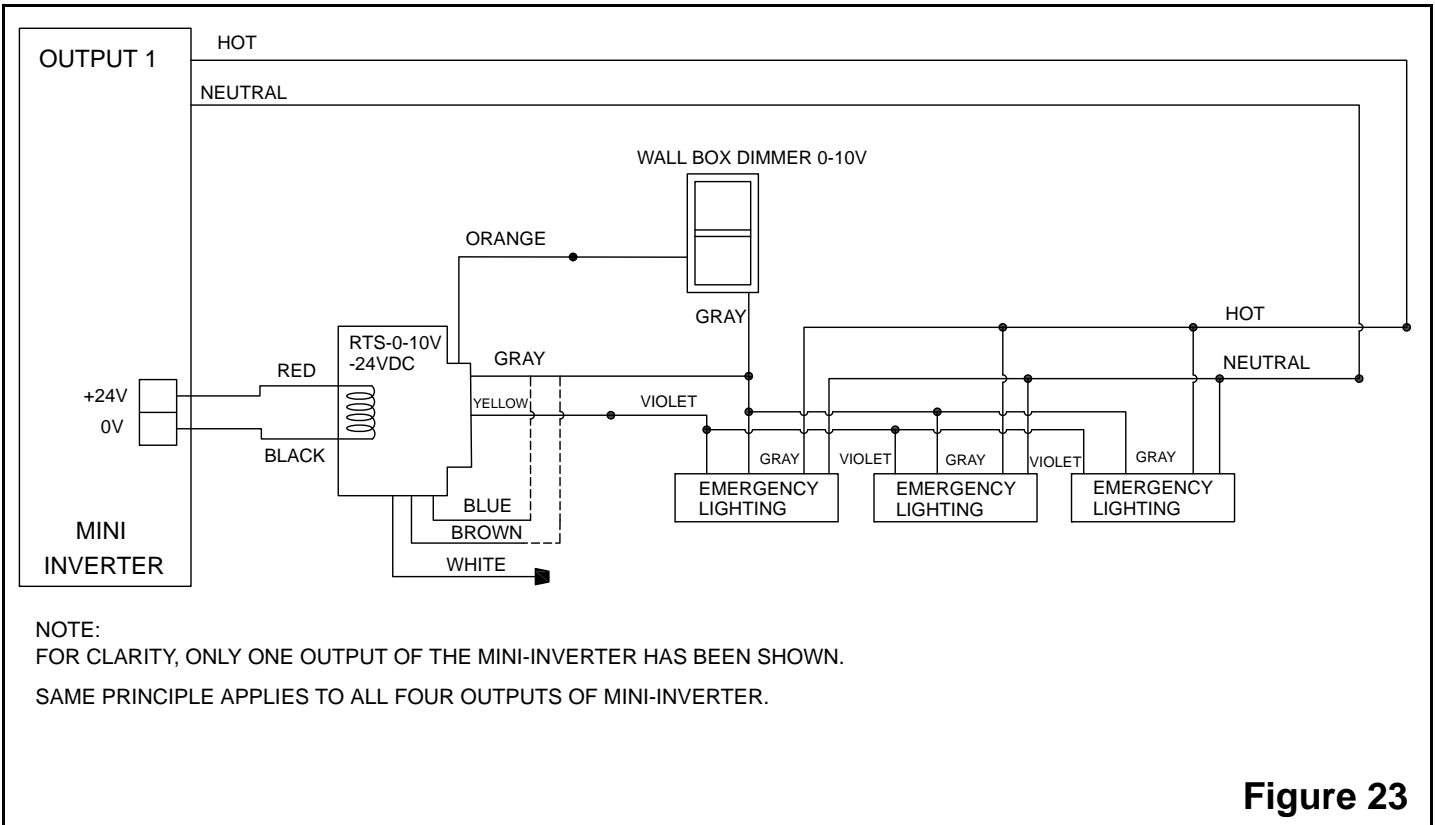

**Figure 23**

- d. When ac utility power is present, the lighting load is controlled by 0-10V wall dimmer. During a power outage, the load is dimmed at pre-set level, depending on the configuration of the RTS-0-10V-24VDC. Wire according to desired dimming:
  - For approx. 25% brightness, connect brown wire to gray wire and cap off blue wire.
  - For approx. 40% brightness, connect blue wire to gray wire and cap off brown wire.
  - For approx. 45% brightness, connect brown and blue wires to gray wire.
  - A maximum of 20 fixtures can be installed per RTS-0-10V-24.



**Important:**

Ensure the total capacity of the dimmed loads does not exceed the rated capacity in Watts and VA of the Mini-Inverter.