

EL-2RHL Series

High output lithium LED battery unit



Housing

- UV stabilized thermoplastic body
- Two adjustable high output LED lighting heads
- White finish

Mounting

- Wall or ceiling mount
- Universal J-box mounting

Lamp type

- Two 9.6V-5.4W LED heads, 550 lumens per head

Electronics

- Pulse plus charger
- Low voltage disconnect
- Automatic brownout protection
- Battery lock-out
- Fused output circuit
- Standard Advanced Diagnostics
- 120/277 60Hz

Approvals

- UL 924 Listed
- Damp location (50°F to 104°F)
- UL 94, 5VA flame rated
- Circle BC meet CEC title 20

Warranty

- Unit has a three-year warranty
Detailed warranty terms located on page 178
of the catalog or online at:
www.emergi-lite.com/usa/files/EL_Warranty.pdf

Photometry performance

| Spacing center-to-center (feet) | |
|---------------------------------|-----------------------|
| Mounting height | 6 ft spacing distance |
| 7.5' | 90' |
| 10' | 78' |

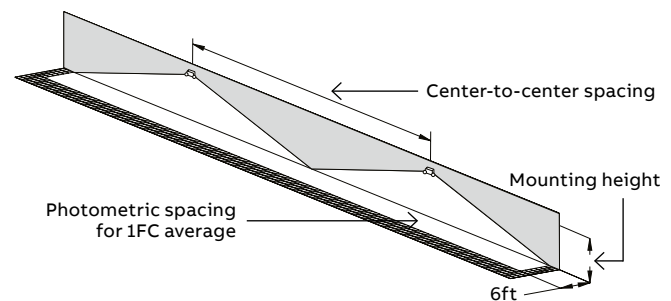

Dimensions

Dimensions are approximate and subject to change.

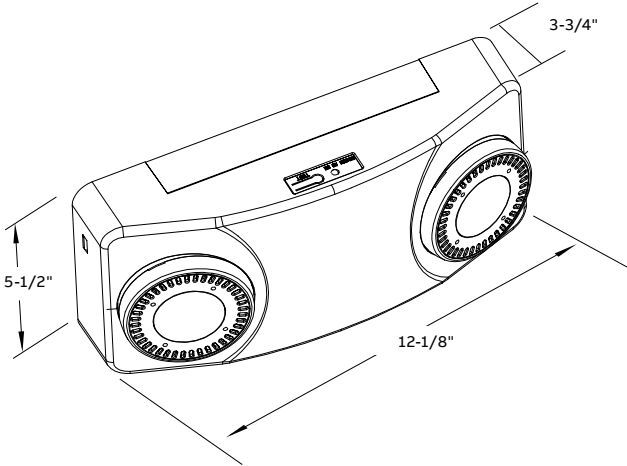

Power consumption and unit rating

| Model | Battery type | DC specs | AC Specs |
|------------|---------------------|----------|--------------------|
| | | Voltage | Units dual voltage |
| EL-2RHL-AD | Lithium-ion battery | 9.6 | 120-277 |

How to order

| Series | Heads |
|--------|---|
| EL | -2RHL-AD= Two round high output LED heads with Advanced Diagnostics |

Example: EL-2RHL-AD