



THE **ESCORT** Model SERIES **EL-2SQ Series**

UL Listed

Complies with NEC, Life Safety Code and OSHA.

Damp location listing is standard in all models.

Sealed Maintenance Free Batteries

- Lead-Calcium



The EL-2SQ Series may be wall or ceiling mounted. Add the fact that the EL-2SQ Series is damp location listed, installs in minutes and you have a very versatile job site solution for emergency lighting. Thermoplastic Emergency Lighting unit with adjustable lighting heads.

Standard Features

Reliability

- The EscortII EL-2SQ series has a three-year full warranty (excluding lamps and fuses).

Housing

- Injection-molded UV stabilized thermoplastic housing and backplate
- UL 94, 5VA flame rating
- Innovative, snap-together design allows for fast installation
- Two fully adjustable glare-free light heads for egress light

Mounting

- Wall or ceiling
- Universal knock-out pattern on the backplate allows for junction-box mounting.

Electrical Features

Electrical

- 120/277VAC, 0.1/0.05 Amp, 60Hz dual voltage operation
- LED indicator light and push button test switch
- Remote capacity - may power additional remote heads (up to 6V 11W).
- Low voltage battery disconnect
- All models are damp location listed

Lamps

- 2 x 6V 5.4 watts DC T5 wedge base lamps for emergency mode

Battery

- Sealed maintenance-free Lead-Calcium battery designed to power 11 watts remote load or extended unit run time.

THE ESCORT Model EL-2SQ SERIES

Outline and Dimensions

Dimensions are approximate and subject to change.

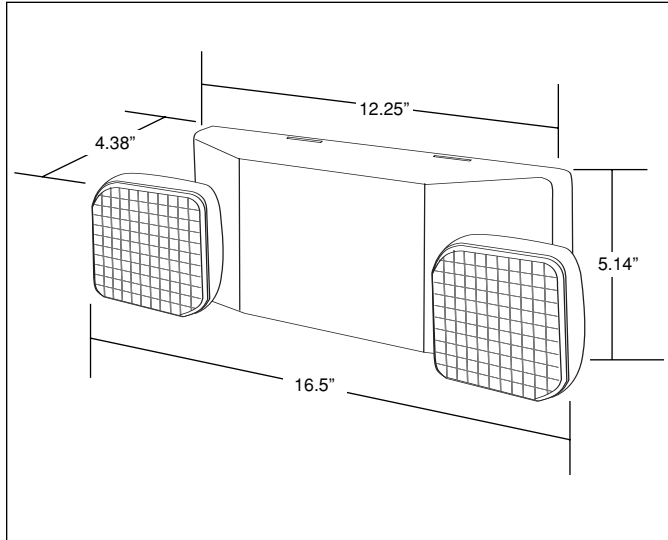

Optional Features

Description	Add Suffix
*Remote Capacity (in watts)	R
Accessories (order as a separate item)	
Replacement battery860.0018
Replacement lamp (standard)570.0012
Vandal shield.....	VRS.BB
Vandal shield (NEMA 4X)	VRSBB.4X
Wire Guard (heads in any position).....	WG10

Note: Certain option combinations may effect the listing.
Please contact the factory for specifics.

How To Order

EL	2SQ	R
<i>Series</i>	<i>Light Heads</i>	<i>Capacity Indicator</i>
Self-powered	Standard Lamp 6V 5.4W Incandescent	Blank = no remote capacity R = 11 watts remote capacity*

* Do not exceed rated unit capacity.

Suggested Specification

The contractor will install the Emergi-Lite _____ battery unit. The emergency lighting system shall consist of fully automatic equipment with 2 MR16 glare free halogen heads. Each unit shall contain a fully automatic, solid state charger with test switch and AC on pilot light. The unit shall contain a solid state transfer circuit and low voltage disconnect circuit. The battery shall be 6 volts with a design life of 8 years with a capacity of 12 watts for 90 minutes. The unit shall be UL924 listed.

Note: This unit does not have remote capabilities. For units with remote capacity please refer to the DLM-2 series.

*Unit Warranty

Entire unit (excluding lamps) carries a 3-year Full Warranty.

*Battery Warranty

Sealed Lead-Calcium: 8-year life expectancy. 3-year Full Warranty, plus 3-year pro rata warranty.

**Subject to proper installation and maintenance.*