



THE **ESCORT II**  
 SERIES

**EL-2MRS Series**

**UL Listed**

Complies with NEC, Life Safety Code and OSHA.

**Damp location listing is standard**

**Sealed maintenance-free batteries**

- Lead-Calcium



The EL-2MRS Series is perfect for use where style and design is required in an economical package. The compact design, measuring only 5-1/2" by 12-1/8", will accommodate the space restrictions often encountered. Six volt, MR16, lamps are powered by a maintenance-free, Lead-Calcium battery to provide a clean, adequate amount of light. The snap-together thermoplastic housing facilitates mounting in any orientation.

**Standard Features**

**Reliability**

The EL-2MRS Series comes complete with a 3-year full warranty (Excluding lamps and fuses).

**Unit Data**

The EL-2MRS is completely self-contained. Constructed of high impact, UL recognized, 94.5VA thermoplastic. Six volt, MR16 halogen lamps, are housed in adjustable, gimbal-type, assemblies. All units are damp location listed.

**Reliable Integrated Circuitry**

The EL-2MRS Integrated Circuitry offers a 120/277 Vac 0.1/0.05 Amp input as standard. As well as automatic charging, instantaneous transfer, test switch, long-life LED AC charge monitor, temperature compensated charger, short circuit protection, low battery voltage disconnect, brownout protection, and lockout (automatic battery detection during installation).

**Outline and Dimensions**

Dimensions are approximate and subject to change

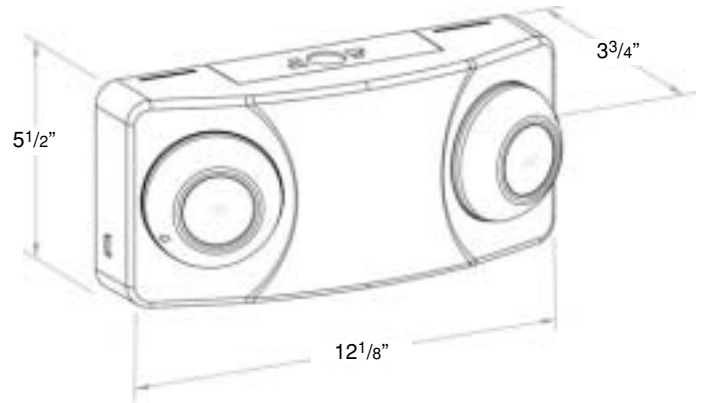

**Accessories (order as a separate item)**

- Replacement MR16 lamp .....580.0072
- Wire Guard .....WG-13

Example: EL-2MRS

**Ordering Format**

Series	Lamp Option
EL = series	Light Heads 2MRS = 6V5W MR16 Halogen