



Premier Series

Specification-grade,
LED Thermoplastic,
universal-mount, snap-fit exit sign

Replaces Escort (ECL) Series



The **Emergi-lite Premier Series** is a compact exit sign with an all-in-one, snap-fit design. Easy to install and affordable, the Premier Series exit sign is ideally suited for commercial and spec-grade applications.

Standard Features

- Durable, injection-molded, thermoplastic housing
- Standard Universal, supplied with two faceplates, backplate for wall mount and easy install canopy for end and ceiling mounting
- Universal, field-selectable snap in/out chevrons
- Indirect refractive technology provides bright, even illumination
- Long-life LED light source assures low maintenance costs and superior illumination
- Energy efficient power consumption: less than 3.5 watts for selfpowered version and less than 3 Watts for AC only single or double face
- Dual voltage input: 120 / 277Vac
- UL924 listed
- All models are UL listed for damp location
- Optional Advanced Diagnostic circuitry, flasher/buzzer, fire alarmactivated flasher
- Optional vandal-resistant shield with tamper proof screws

Typical Specifications

Supply and install the **Emergi-lite Premier** exit sign. The standard equipment shall operate with a dual-voltage input of 120/277Vac with less than 3.5 Watts of consumption. The exit shall be suitable for wall, end, or ceiling mount. The faceplate shall be constructed of a durable high impact thermoplastic and come standard with snap in/out chevrons. No screws are necessary to hold the faceplate or the back plate to the housing. The one piece thermoplastic frame is molded in white (optional black). The light source shall be light emitting diodes (LEDs). The LEDs shall provide illumination in normal and emergency operation and shall be mounted inside the exit housing. The light source shall be long-life LEDs installed in a PSB strip. A LED-sensitive diffuser shall be mounted in front of the LEDs to provide the 6" high by ¾" stroke letters with even illumination. The exit sign in a self-powered configuration shall be equipped with a sealed, maintenance-free Nickel-Cadmium battery. The equipment shall stay illuminated at least 90 minutes upon AC failure. The exit sign shall be listed to UL924 standard and be approved for use in damp locations.

The self-powered model equipped with optional advanced diagnostic shall self-test by simulating a power failure for one minute every 30 days, 30 minutes every 60 days and 90 minutes every 360 days. A diagnostic circuit shall continuously monitor the performance of the battery, charger module and LED lamps. Upon failure detection the system shall display the error on the AC pilot lamp, which will change color from green to red and will flash with a specific code. The pilot lamp shall be steady-on red in case of "Battery Disconnect"; it shall flash red with one blink for "Battery failure", two blinks for "Charger failure" and four blinks for "LED lamp failure. A label with the diagnostic legend shall be visible next to the pilot lamp.

The exit sign shall be Emergi-lite Model - _____.

Outline and Dimensions

Dimensions are approximate and subject to change.

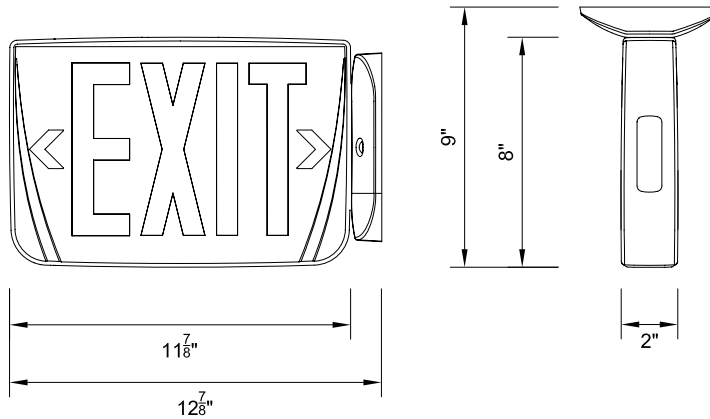

Accessories (Order as a separate item)

Wire Guard

Wall Mount WG1-E
 Ceiling or End Mount.....WG5-E

Unit Warranty*

5 years full warranty.

*Subject to proper installation and maintenance.

How To Order

Example: WPREMACR

Housing Color	Series	Unit type	Legend color / No. of Face	Options
W = White B = Black	PREM = LED plastic EXIT	<p><i>Standard Models</i></p> <p>AC = AC only (120/277 volts) U = 120/277vac & 6 to 48vdc SNX = self-powered NiCad</p> <p><i>Optional Models</i></p> <p>2C1 = dual AC circuit (2x120 volts) 2C2 = dual AC circuit (2x277 volts) DN = self-powered diagnostic NiCad </p>	<p>R = Red Universal R1 = Red single face* R2 = Red double face* G = Green Universal G1 = Green single face* G2 = Green double face*</p> <p><i>Open face</i></p> <p>RW = Red on White GW = Green on White</p> <p>Open face required with special wording legends.</p>	<p>BA = Brushed aluminum stencil FZ = Flasher buzzer (DN model only) FL = Flasher (DN model only) FA = Fire alarm activated flasher (AC, U, 2C1, 2C2 and DN models only) FBF = Flasher buzzer + fire alarm activated flasher (DN model only) *VR = Tamper proof screws *VR1 = Polycarbonate shield with tamper proof screws</p> <p>*please specify single or double face, Red or Green.</p>