

# Prestige DX & DXN - Die Cast Aluminum LED Exit Series

AC, AC/DC, Self-Powered and Nexus

## IMPORTANT SAFEGUARDS

When using electrical equipment, basic safety precautions should always be followed including the following:

## READ AND FOLLOW ALL SAFETY INSTRUCTIONS

1. Do not use outdoors.
2. Do not let power supply cords touch hot surfaces.
3. Do not mount near gas or electric heaters.
4. Equipment should be mounted in locations and at heights where it will not readily be subjected to tampering by unauthorized personnel.
5. The use of accessory equipment not recommended by the manufacturer may cause an unsafe condition.
6. Do not use this equipment for other than intended use.
7. All servicing should be performed by qualified service personnel.

## SAVE THESE INSTRUCTIONS

### Installation Instructions

1. Turn off AC unswitched power.
2. Route AC unswitched circuit of rated voltage into electrical box and leave 6" of wire length.
3. Separate the housing assembly, back cover and exit door, using a screwdriver (see fig. 3).

#### Canopy mount

- a. Separate the canopy plate from the canopy assembly and retain the securement screw (see fig. 2).
- b. Remove the proper knockout in the canopy plate for desired mounting position.
- c. Feed the AC unswitched wires through the large hole in the canopy plate. Use the junction box screws to secure the canopy plate to the junction box. Ensure the location for securement screw is accessible.
- d. To knock out the chevrons, remove the diffuser panel. Support the door around the chevrons with two blocks of wood. Strike arrow knockouts from the inside with a hammer and screwdriver. Re-install the diffuser panel using the securement clips (see fig. 3).
- e. Determine which side of the exit frame will be used for mounting. Break out the appropriate rectangular section at the canopy mounting position (see fig. 3). Make sure edges are free from burrs.
- f. Secure the canopy to the exit housing by guiding flange on the canopy into the rectangular hole in the side (or top) of the hous-

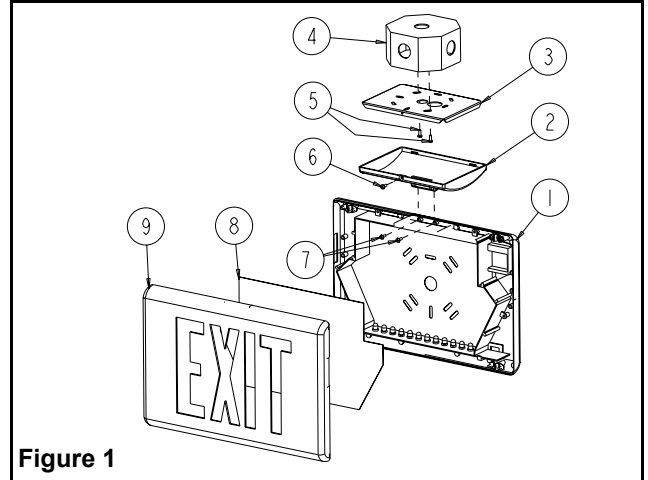

Figure 1

#### Part List

- |                                       |                     |
|---------------------------------------|---------------------|
| 1. Back cover                         | 6. Securement screw |
| 2. Canopy                             | 7. Canopy screws    |
| 3. Canopy plate                       | 8. Diffuser Panel   |
| 4. Junction box (not supplied)        | 9. Exit door        |
| 5. Junction box screws (not supplied) |                     |

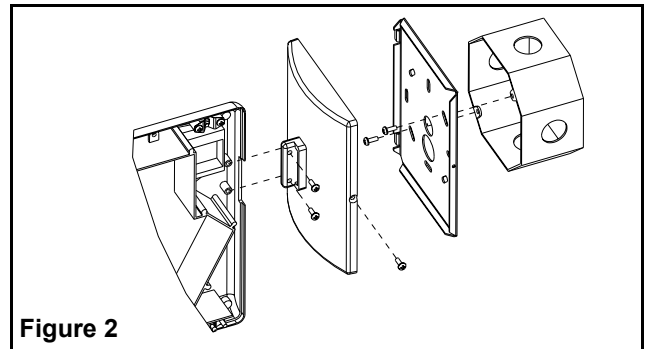

Figure 2

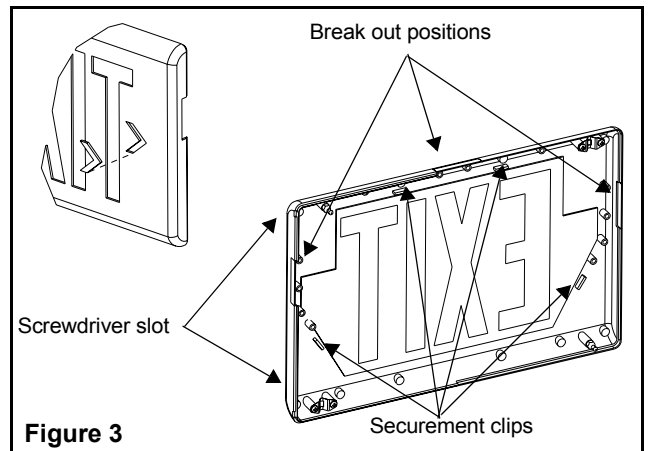

Figure 3

- ing. Use the canopy screws to fasten the canopy to the housing (see fig. 2).
- g. Route the AC supply wires and ground wire from the exit through the rectangular hole in the exit housing and through the slot in canopy. Make the proper connection. Our system can accept input voltages from 120 to 347 VAC. Therefore, connect the purple (hot) and white (common) leads to the building utility (see fig. 5). For master exit sign wiring, connect the orange (277 VAC) or the black (120 VAC) and the white (neutral) to the building utility. Feed the excess wire into the junction box.
- Note** — For the Nexus models wiring, go to the section “Nexus Models” (see fig. 7).
- h. Mount the exit/canopy assembly to the canopy mounting plate by guiding the two tabs on the canopy plate into the slots in canopy. Use the securement screw to fasten the canopy to the mounting plate (see fig. 2). Go to step 3.

### Wall Mount

- a. No canopy required. Determine the proper knockout in the back cover for mounting. Support the area around knockout with two blocks of wood. Strike knockouts from the inside with a hammer and screwdriver (see fig. 4). Follow the chevrons knockout procedure in the Canopy mount section, step e.
- b. Route the AC unswitched wires through the large hole in the back cover.
- c. Mount the back cover to the junction box using the junction box screws.
- d. Make the proper connections. Our system can accept input voltages from 120 to 347 VAC. Therefore, connect the purple (hot) and white (common) leads to the building utility. For master exit sign wiring, connect the orange (277 VAC) or the black (120 VAC) and the white (neutral) to the building utility. Feed excess wire into the junction box (see fig. 5)
- Note** — For the Nexus models wiring, go to the section “Nexus Models” (see fig. 7).
4. Snap the two halves of clampshell together.
5. Energize AC. Sign will illuminate.
6. Units with vandal resistant options, refer to fig. 6.

### AC/DC Models

Refer to fig. 5 for AC & DC wiring.

**For DC portion** — Wire the Red lead (+) to the positive DC input voltage and the Blue Lead (-) to the negative DC input voltage. Note: DC input voltage range is 6 volts to 48 volts.

### Nexus models

Refer to figure 7 for the wiring of Nexus models.

These units can accept an input voltage of 120 or 277 VAC:

**120 VAC** — Connect the black (120 VAC) lead and white (neutral) lead to the building utility. Insulate the orange wire.

**277 VAC** — Connect the orange (277 VAC) lead and white (neutral) lead to the building utility. Insulate the black wire.

Feed excess wire into the junction box.

Leave as much space as possible between the live voltage cabling and the unshielded low voltage data cabling.

Run the double insulation of data cables past the line cabling section and only strip back the last 30mm of the data cable sheathing.

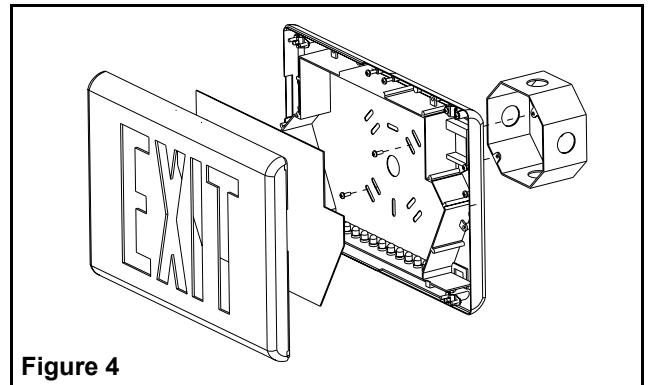

Figure 4

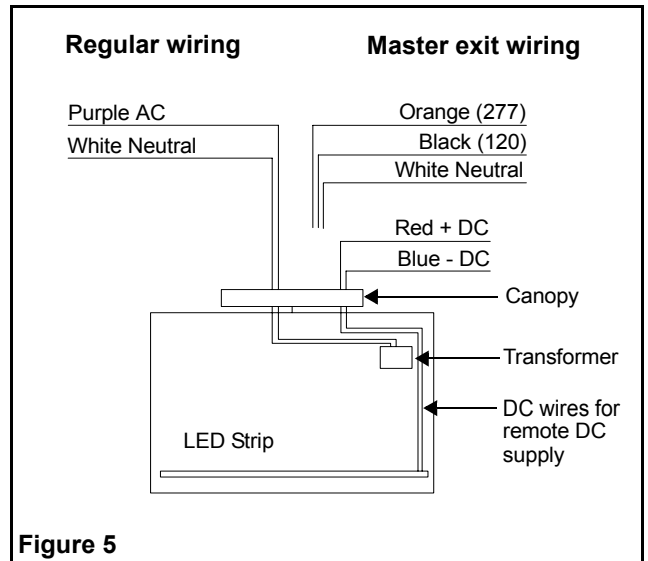

Figure 5

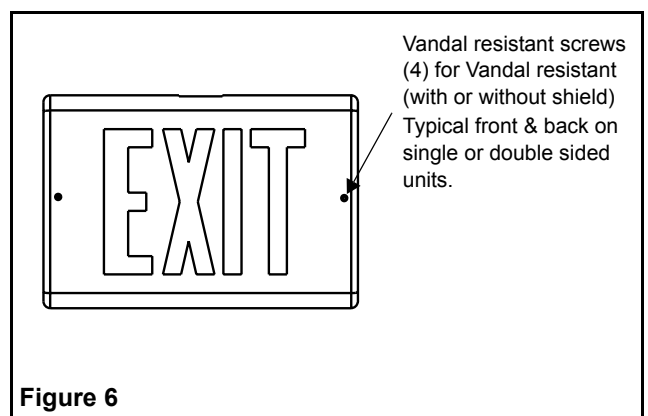

Figure 6

**Self-Powered Models**

**Manual testing**

Press test switch. Legend will flicker, but remain lit, AC pilot lamp will extinguish. On release, pilot lamp will illuminate, and automatic charger will restore battery to full charge.

**Automatic testing and diagnostic**

All models have automatic testing and diagnostics which includes a micro-controller that exercises, self-tests, the unit on a monthly basis and identifies and displays failures of the electrical components: battery, battery charger, lamps, LEDs.

**Self-test**

The self-test is performed every 30 days for 30 seconds, every 60 days for 30 minutes, and annually for 90 minutes.

**Diagnostic function**

The diagnostic function uses three red LED indicators: one external, near AC pilot lamp, and two internal, inside the unit. The unit has to be opened to read the status of the internal indicators.

External: Service Required. Blinks if any alarm condition is detected (See fig. 8).

Internal: Battery Alarm, Charger Alarm. Steady ON if alarm condition exists (See fig. 9).

**Normal operation, No fault** — Service Alarm is OFF and one of the two internal LED blinks, showing that the micro controller is active.

**Faulty operation** — Service Alarm blinks.

Battery Alarm ON, Charger Alarm OFF: Check battery or replace battery.

Battery Alarm ON, Charger Alarm ON: Check LED strip.

Battery Alarm OFF, Charger Alarm ON: Check charger circuit.

**Nexus models**

Nexus models use two local indicators. One is a green LED for AC pilot lamp. The other is a tricolor LED (Service) which identifies and displays the Nexus status. The table below describes each status:

**Nexus Tricolor LED — Status table**

	<i>Uncommissioned</i>	<i>Commissioned</i>
Normal	Red/Off pulsing	Green steady
Under test	N/A	Green/Off pulsing
Wink mode	Yellow-orange/(red or off) pulsing	Yellow-orange/Off pulsing
Neuron faulty	Red Steady	Red steady
Power fail	Off	Off
Battery disconnected	N/A	Off

**Caution**

*This unit is an integral component of a remotely monitored and controlled self-test/self-diagnostic emergency lighting system. In the event that control is suspended or becomes inoperable, this unit may have to be manually tested as required by local code regulations.*

**Maintenance**

None required. If AC supply to the unit is to be disconnected for 2 months or more, the battery must be disconnected, Self-Powered Models only.

**Note** — Nickel Cadmium battery units are shipped discharged and may require 10 minutes of connection to AC supply before start-up test procedure, and 96 hours to reach full charge or 24 hours to reach a 30 minute discharge.

