



## THE ESCORT FAMILY

### X30 LED Mini-Systems

Evaluated to UL 924 Standard

#### Light Sources

- LED, Light Emitting Diodes, red LED's of ALINGAP technology
- Emergency Heads, two 6V, 5.4 watt high intensity incandescent lamps

#### Sealed Maintenance-Free Batteries

- Lead-Calcium
- Nickel-Cadmium



### Standard Features

- Rugged thermoplastic construction in white or black.
- LED based even illumination for excellent legibility.
- Red LEDs ALINGAP technology.
- Stencil and open face signs have programmable directional arrows.
- Removable face and backplate makes it easy to convert sign for either single or double face applications.
- Sealed maintenance-free Lead Calcium battery.
- Batteries provide 90 minutes of emergency operation.

#### Charger

- 120/277 dual voltage input
- Fully automatic charger
- Temperature compensated
- Low voltage battery disconnect
- Brownout protection
- Lockout (automatic battery connect)
- Combination AC pilot light / test switch

### PulsePlus Diagnostics

We've taken our standard PulsePlus circuitry, with all its features, and added diagnostics that continuously monitor every critical function of the unit and use five colored LEDs to indicate operational status. GREEN...AC On, AMBER...Float Charge, RED...Pulse Charge, RED...Lamp Failure, RED...Battery Failure.

### Suggested Specifications

Supply and install Emergi-Lite ESCORT X30 Series of plastic mini systems shall be listed to U.L. Standard 924. Exit frame, backplate, faceplate and mounting canopy shall be of thermoplastic construction in black or white. The exit sign knockouts are on the top and side for canopy mounting, and a universal knockout pattern is on the backplate to provide alternate mounting capability.

**The Unit:** shall provide a minimum of 90 minutes of battery powered emergency illumination to the exit signs and emergency lights. **Chargers Circuits:** shall be fully automatic, solid state, temperature compensated and short-circuit protected. **Batteries:** shall be completely sealed and maintenance-free. Construction shall be Lead Calcium for Long-Life Lead. **Circuitry:** shall include a LED pilot light and test switch. Electrical features shall include low voltage disconnect, brownout protection and battery lockout.

**Power Consumption:** 120/277 Vac 60Hz, 0.3/0.15 Amp  
**Unit Rating Chart** (total DC power available for local and remote emergency lights)

Battery Type	DC Voltage	Model Number	Watts to 87 1/2% of rated battery voltage			
			1 1/2 Hrs.	2 Hrs.	3 Hrs.	4 Hrs.
Lead-Calcium	6	SBX34	30	20	15	10
Nickel-Cadmium	6	STX34	24	18	12	9

## Outline and Dimensions

Dimensions are approximate and subject to change.

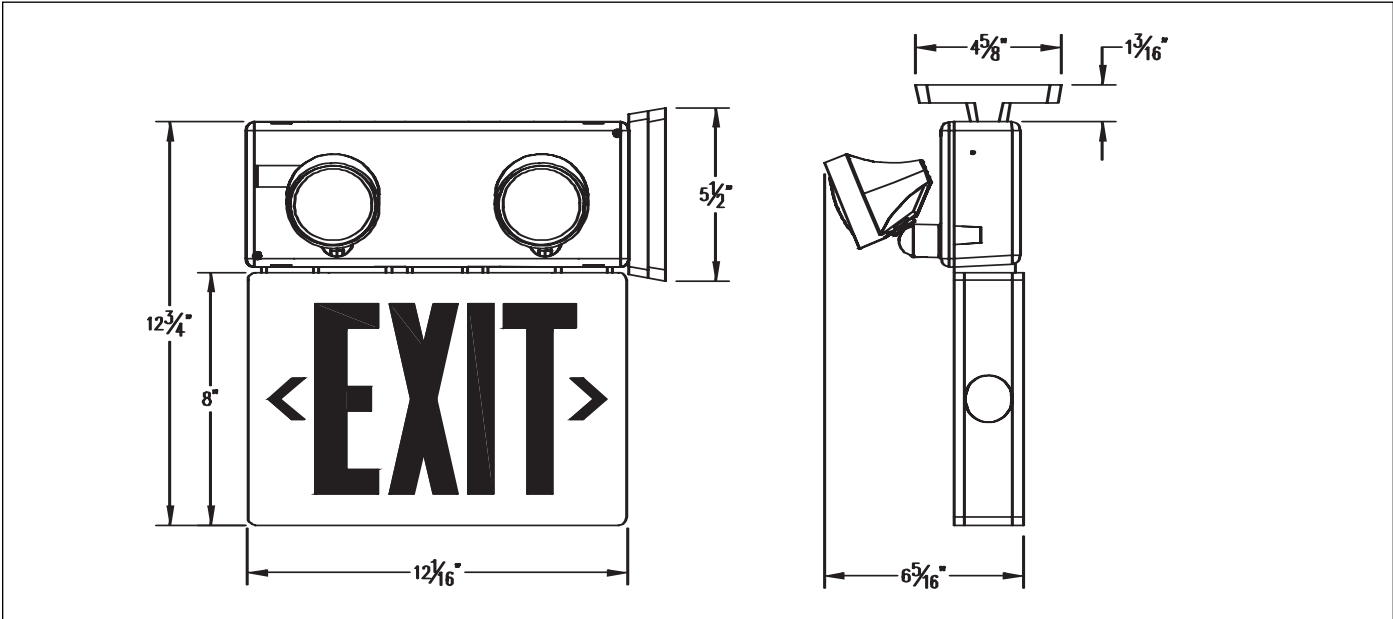

## Optional Features

Description	Add Suffix
Non-standard input voltage .....	Specify
Vandal resistant screws .....	-VR

NOTE: Certain option combinations may effect the listing.  
Please contact the factory for specifics.

## Accessories (order as a separate item)

White Pendant .....	P*-WT
Black Pendant .....	P*-BK
Wire Guard, Wall Mount .....	WG6

\*Specify pendant length (12", 24" 36", etc)

## How To Order (example)

L	W	SBX	34	R	29	-VR
AC Lamp	Housing	SBX=Sealed	Series	Face	Mini Systems	Options
L=LED	Color	Lead-Calcium	34=Universal;	Stencil Face	#of heads	See Optional
	W=White	STX=Nickel-Cadmium	Double face, with	R=Red	19=1 head	Features
	B=Black		canopy and back-	G=Green	29=2 heads	
			plate	Open Face*	Blank=0 heads	
				RW=Red/White		
				WR=White/Red		
				GW=Green/White		
				WG=White/Green		

\* Open face sign required for special wording

## Unit Warranty\*

Entire unit (excluding lamps) carries a 3 year full warranty.

## Battery Warranty\*

Unit Batteries are warranted as follows:

Sealed Lead Calcium – four years life expectancy

Sealed Nickel-Cadmium- 10 years life expectancy

5 years full warranty plus 5 years pro rata warranty

\*Subject to proper installation and maintenance

## Head Mounting Choices with the LED Exit Sign.

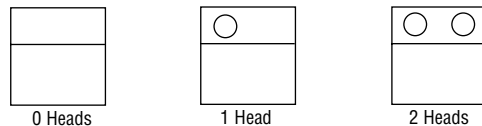

**The Economy Class:** this series is still available with incandescent exit signs. Call factory for details.