



Lux-Ray Series

Now with white LED normally-on option



Standard Features

Reliability

The Lux-Ray Series comes complete with a 3-year full warranty (excluding fuses and incandescent lamps).

Unit Data

The Lux-Ray units are made of durable cast aluminum housing, finished with textured polyester powder coat paint. Four colors are available: off white, black, platinum gray and dark bronze.

The vacuum-plated die-cast reflector will last over time. The lens is made of an impact and UV resistant polycarbonate.

The unit can be installed on various junction boxes with universal mounting pattern. It can also accept a surface mount cable, via the rigid conduit entry provision on the top of the unit.

Lamp information

The Lux-Ray units are furnished with two high-output Xenon lamps for emergency lighting. These lamps, combined with a patent pending reflector, deliver an incredible center-to-center spacing. The reflector has been designed to provide an evenly distributed illumination pattern for corridors, up to 6' wide.

Charger

All self-powered units come with a dual-input 120/277Vac, 60Hz. Chargers also include low voltage disconnect to prevent deep discharge, battery lockout to prevent battery drain prior to energizing the utility power, brownout protection which will automatically switch unit into emergency mode if the utility power falls below 80% of nominal and battery reverse polarity protection.

Lead-Calcium Models are equipped with the Pulse Plus circuitry that will promote long battery life and excellent performance. This current limiting charger will minimize energy consumption.

Nickel Metal Hydride Models are equipped with the non-audible version of the Advanced Diagnostics system (ADNA). This charger is a self-test and self-diagnostic charger. It will monitor and indicate any of the following failures: battery disconnect, battery, charger and lamp failures. The unit will perform a periodical self-test, of minimum 30 seconds every 30 days, 30 minutes every six months and 90 minutes annually. Discharge test can also be initiated manually.

Controls or electrical

- Lead-Calcium Models: red LED indicates AC power is on.
- Nickel Metal Hydride Models: bi-color LED indicates battery state of charge, test activation and four-state diagnostic status.
- Test switch allows for quick operational check of the entire system.

Power Requirements

120/277Vac, 60Hz, 0.11/0.05 Amp

Suggested Specification

White LED – Accent Light Lux-ray with dual-mode illumination (optional)

•General

The dual-mode illumination feature enables the Lux-ray to provide lighting not only during power outages, but also in normal conditions. This is achieved with a secondary light source, a long-life, 5-watt power LED lamp dedicated to normal lighting.

When equipped with this feature, the equipment includes two independent circuits, electrically isolated from each other: the standard input for emergency lighting and a secondary input for normal lighting. The secondary input can be connected to a regular AC line that may include an electric switch. The dual-mode illumination option is available with any model of Lux-ray unit:

= Battery-operated (self-powered): Lead-Calcium (6V 12W), NiMH (6V20W) and NiMH extreme temperatures (6V 12W)

= DC-remote: 6Vdc or 12Vdc; 2 x 6W or 2 x 10W Xenon lamps

• Electrical

The Lux-ray LED lamp for normal lighting utilizes one five-watt white LED supplied with a simple and robust ballast circuitry.

= AC input: dual voltage 120/277Vac, 0.04A, 5W

= LED lamp operational life: 50,000 hours (till 70% of initial light level)

Battery Replacement

840.0004-E 6V12W Lead Calcium

850.0086-E 6V12W, 20W NiMH

Lamp Replacement

570.0213-E ZU= 6V6W Xenon

570.0214-E ZV= 6V10W Xenon

570.0215-E ZW= 12V6W Xenon

570.0216-E ZX= 12V10W Xenon

Outline and Dimensions

Dimensions are approximate and subject to change.

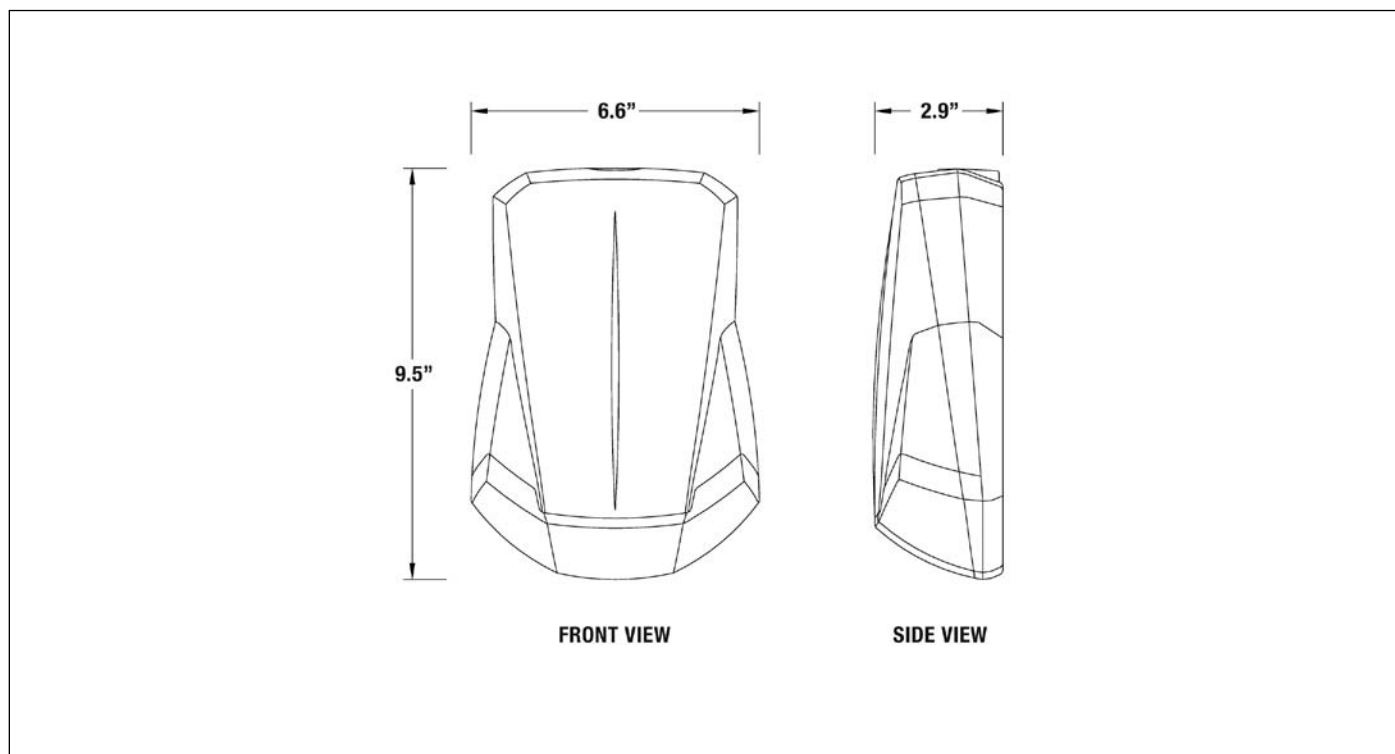

How To Order Battery Unit

Example: OWLUXLZU-D1

| Color | Series | Lamp/Voltage* | Options |
|---|---|--|--|
| OW = off white B = black BZ = dark bronze PG = platinum gray <small>*Other colors available at a premium. Please contact your sales representative.</small> | LUXL = 6V - 12W, lead calcium (+20°C to +30°C) Pulse Plus charger LUXN = 6V - 12W, NiMH (-20°C to +40°C) comes with advanced diagnostic non-audible (ADNA) LUXN2 = 6V - 20W, NiMH (+20°C to +30°C) comes with advanced diagnostic non-audible (ADNA) | ZU = 6V-6W ZV = 6V-10W** <small>*Xenon wedge base T3-1/4 **Only available in LUXN2 Other lamps available</small> | -D1 = 5 min time delay* -D2 = 10 min time delay* -D3 = 15 min time delay* -2 = dual-mode lighting <small>*Time delay available only with ADNA, LUXN and LUXN2 units.</small> Limited Warranty: Lead-Calcium Battery= 3 years Nickel Metal Hydride Battery= 5 years |

How To Order Remote Unit

Example: LUX(ZU)-OW-2

| Series | Lamp/Wattage | Color | Options |
|--|---|--|--------------------------------|
| LUX = remote fixture (-40°C to +60°C)* Outdoor remote <small>*Option Dual-Mode Lighting: -40°C to +40°C</small> | (ZU) = 6V-6W (ZV) = 6V-10W (ZW) = 12V-6W (ZX) = 12V-10W Xenon wedge base T3-1/4 | -OW = off white -BK = black -BZ = dark bronze -PG = platinum gray <small>*Other colors available at a premium. Please contact your sales representative.</small> | -2 = dual-mode lighting |