



The **EL-2MRS Series** is perfect for use where style and design is required in an economical package. The compact design, measuring only 5-1/2" by 12-1/8", will accommodate the space restrictions often encountered. Six volt, MR16, lamps are powered by a maintenance-free, Lead-Calcium battery to provide a clean, adequate amount of light. The snap-together thermoplastic housing facilitates mounting in any orientation.

Standard Features

Reliability

The EL-2MRS Series comes complete with a 3-year full warranty (Excluding lamps and fuses).

Unit Data

The EL-2MRS is completely self-contained. Constructed of high impact, UL recognized, 94,5VA thermoplastic. Six volt, MR16 halogen lamps, are housed in adjustable, gimbal-type, assemblies. All units are damp location listed.

Reliable Integrated Circuitry

The EL-2MRS Integrated Circuitry offers a 120/277 Vac 0.1/0.05 Amp input as standard. As well as automatic charging, instantaneous transfer, test switch, long-life LED AC charge monitor, temperature compensated charger, short circuit protection, low battery voltage disconnect, bownout protection, and lockout (automatic battery detection during installation).

UL Listed

Complies with NEC, Life Safety Code and OSHA.

Damp location listing is standard

Sealed maintenance-free batteries

- Lead-Calcium

Outline and Dimensions

Dimensions are approximate and subject to change

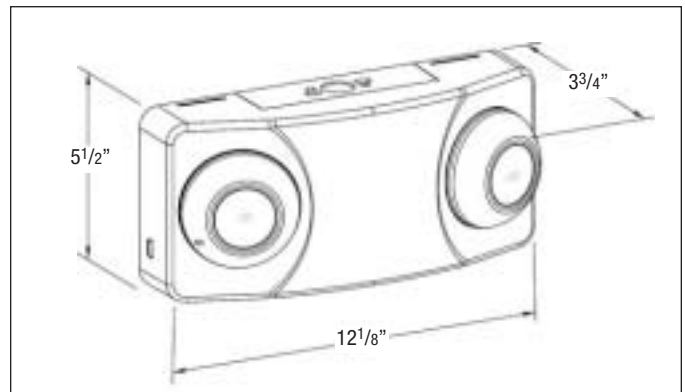

Accessories (order as a separate item)

Replacement MR16 lamp 6V 5W.....	580.0072
Wire Guard	WG-13

How To Order

EL-	2MRS	B
Series	Lamp Option	Colour
	Light Heads	Black
	6V5W MR16	
	Halogen	