



The **EL-2MRS Series** is perfect for use where style and design is required in an economical package. The compact design, measuring only 5-1/2" by 12-1/8", will accommodate the space restrictions often encountered. Six volt, MR16, lamps are powered by a maintenance-free, Lead-Calcium battery to provide a clean, adequate amount of light. The snap-together thermoplastic housing facilitates mounting in any orientation.

UL Listed

Complies with NEC, Life Safety Code and OSHA.

Damp location listing is standard

Sealed maintenance-free batteries

- Lead-Calcium

Outline and Dimensions

Dimensions are approximate and subject to change

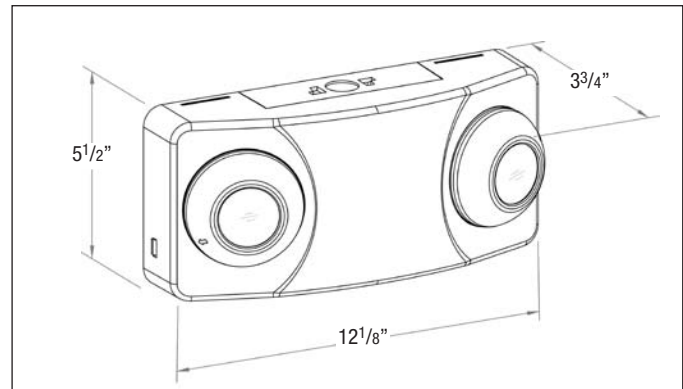

Standard Features

Reliability

The **EL-2MRS Series** comes complete with a 3-year full warranty (Excluding lamps and fuses).

Unit Data

The **EL-2MRS** is completely self-contained. Constructed of high impact, UL recognized, 94,5VA thermoplastic. Six volt, MR16 halogen lamps, are housed in adjustable, gimbal-type, assemblies. All units are damp location listed.

Reliable Integrated Circuitry

The **EL-2MRS** Integrated Circuitry offers a 120/277 Vac 0.1/0.05 Amp input as standard. As well as automatic charging, instantaneous transfer, test switch, long-life LED AC charge monitor, temperature compensated charger, short circuit protection, low battery voltage disconnect, bownout protection, and lockout (automatic battery detection during installation).

Accessories (order as a separate item)

- Replacement MR16 lamp 6V 5W.....580.0072
- Wire GuardWG-13

How To Order

EL-	2MRS	B
Series	Lamp Option	Colour
	Light Heads	Black
	6V5W MR16	
	Halogen	